

Get it from the Science Museum Shop:
shop.sciencemuseum.org.uk

SCIENCE MUSEUM



Was the first electric iron invented before or after the lightbulb? But what if it was actually dated somewhere between the development of canned food and the invention of Babbage's Difference Engine No. 1? And was Uranus discovered around the same time as the Cat's Eye Nebula?

The objective of Timeline Science Museum is to be the first player to play all of your cards correctly in the Timeline!

Available now!

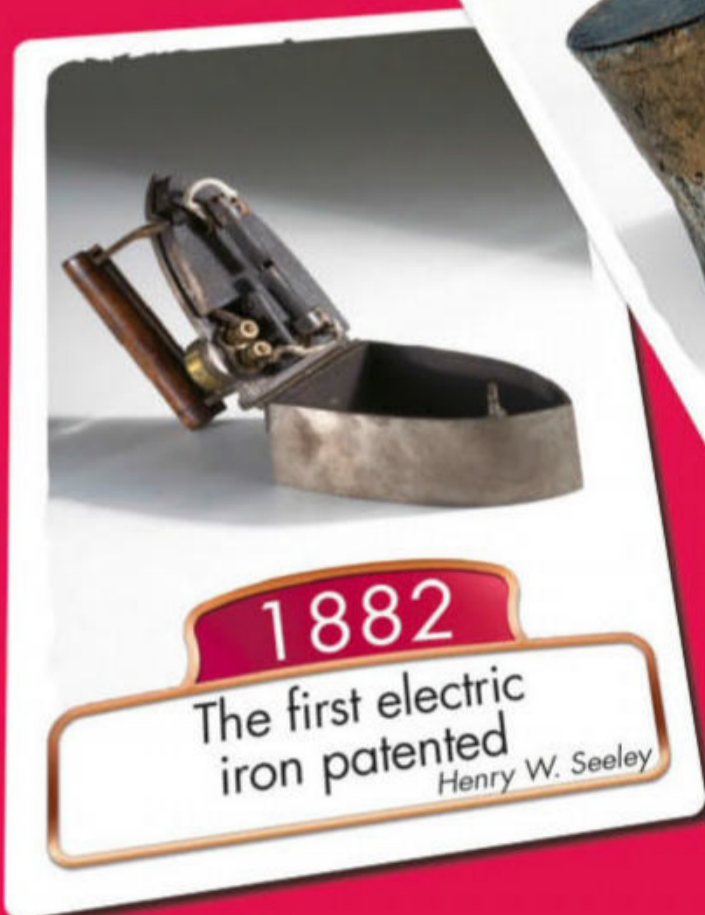

WIN SMART SOLES WORTH **£390**



SOLAR SYSTEM SUPERSTORMS



HOW IT WORKS

FEATURING **LIVESCIENCE**



ROBOT WARS

THIS IS THE FUTURE OF THE ARMY'S BATTLEFIELD

THE MAGAZINE THAT FEEDS MINDS™

POWER OF THE SUN

HOW SCIENTISTS ARE RECREATING A STAR ON EARTH

INSIDE AN **ATOM-SMASHER**
POUNING PARTICLES TO SOLVE SECRETS OF THE UNIVERSE



ANIMAL ANTIDOTES

The beasts that help humans overcome deadly poisons



HOW YOU CAN HELP TO CURE CANCER



HUNTING SCHOOL FOR TIGERS

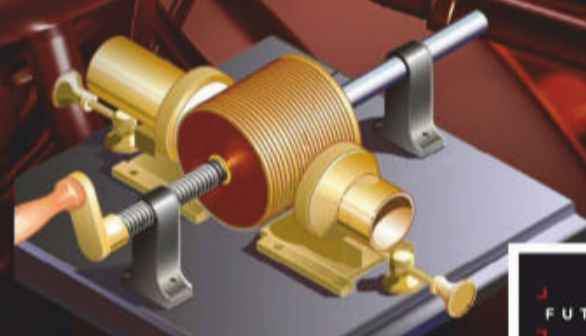

WHAT THE VICTORIANS DID FOR US

FUTURE
ISSUE 123

+ HOW BIG IS THE UNIVERSE? ION WIND PLANE HOW TO READ BRAILLE BREXIT BASICS



**DOWNLOAD
THE DEMO GAME
FOR FREE!**

UNLOCK! EXOTIC ADVENTURES



**Three new
adventures!**

THE CARD GAME INSPIRED BY ESCAPE ROOMS!

Embark on great adventures, search scenes for clues, combine objects and solve puzzles - with only one hour on the clock! Each of these three new adventures captures the pulse-pounding excitement and devilish riddles of an escape room and brings it to your tabletop!



WELCOME

The magazine that feeds minds!

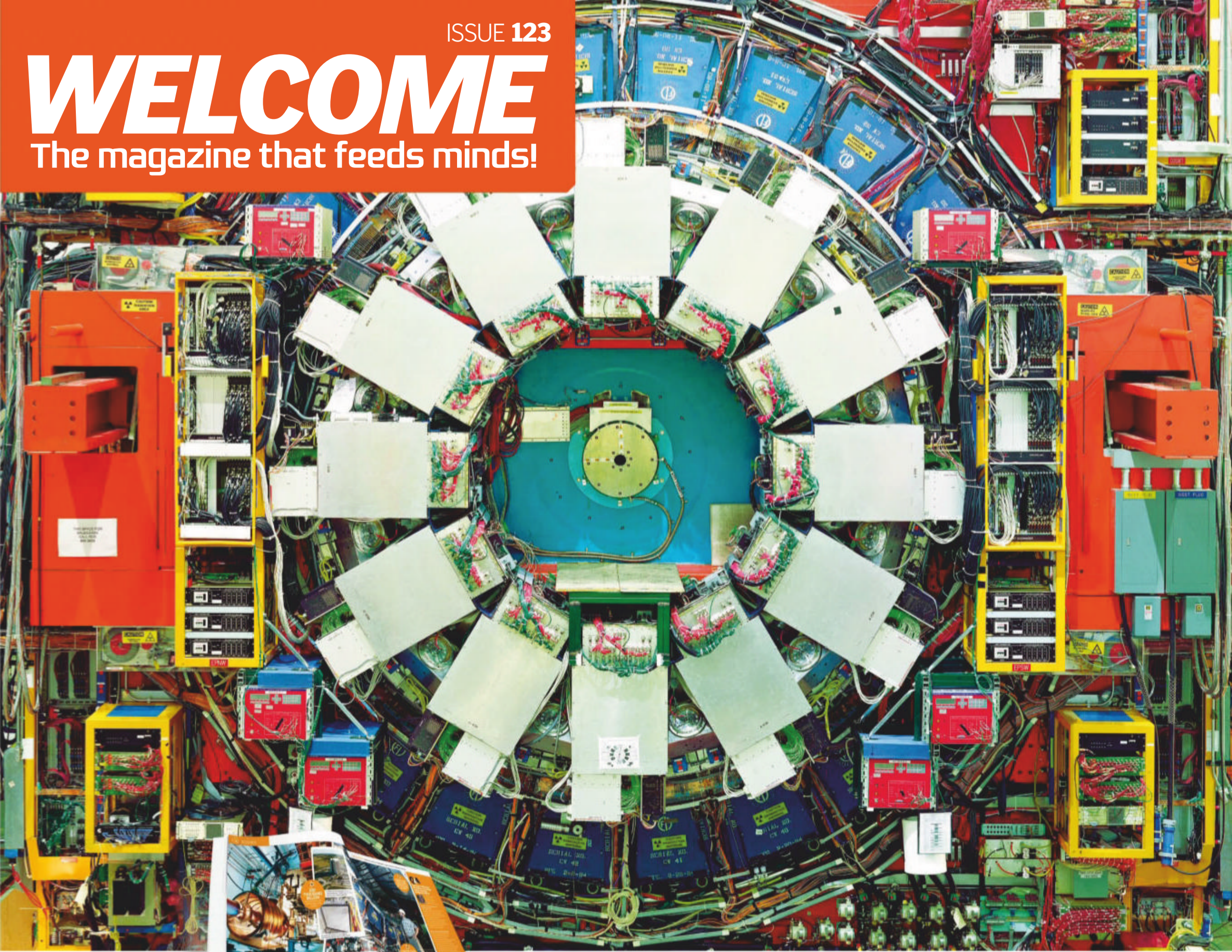

"It's been converting mass into energy for over 4 billion years"

Power of the Sun, page 22

Meet the team...



James
Production Editor
The world's ancient monuments are often under threat, but the technology we explore on page 42 can help us save and restore them.



Scott
Staff Writer
Not every animal is susceptible to the bite of a deadly snake. Discover how some animals are immune to venom on page 48.



Baljeet
Research Editor
If you thought the weather on Earth was bad, see what the rest of the Solar System has to contend with on page 32.



Duncan
Senior Art Editor
We look at just a few of the many inventions the Victorians made on page 78. It's incredible how many we still use today.



If you ask me what the most exciting technological advancement of this century will be, then I would have to answer fusion power. Though the tokamak was invented in the atomic era of the 20th century, creating a fusion reactor that's stable and efficient enough has always seemed tantalizingly out of our reach. We're getting close though, and the potential of successfully harnessing the same power that allows a star to generate almost incalculable amounts of energy will be a game-changer for planet Earth. Imagine being able to replace dozens of fossil fuel stations and nuclear fission reactors with a single fusion power station, generating enormous amounts of cheap energy that produces zero greenhouse gases and radioactive waste. Read about the science behind this incredible technology on page 22. Enjoy the issue!

Ben Biggs Editor

For exclusive HIW news and offers, sign up to our mailing list
howitworksdaily.com/newsletter

FOLLOW US...

How It Works magazine @HowItWorksmag

CONTENTS

SPECIAL

- 22 Power of the Sun**
What makes our nearest star so energetic, and how can we recreate this on Earth?

SPACE

- 32** Solar System superstorms
36 Determining the size of the universe

TECHNOLOGY

- 38 Inside a robot warehouse**
These smart machine workers could be handling your next online order

- 42** Rewinding time
46 How to read Braille

ENVIRONMENT

- 48 Antidote animals**
How some animals are immune to deadly poison – and how this can help humans
- 52** Why spring happens
54 What are atmospheric rivers?
56 How tigers hunt

SCIENCE

- 58 Inside an atom-smasher**
How It Works visits Fermilab and discovers how it's trying to solve the mysteries of the universe
- 64** Heroes of science: Cecilia Payne-Gaposchkin
66 Finding cures for cancer
68 What is a mouth ulcer?

TRANSPORT

- 70 Robot wars**
Discover the autonomous technology that will change the battlefield forever
- 74** What is an ion wind plane?
76 Super-sucking excavator trucks

HISTORY

- 78 What the Victorians did for us**
How inventors 200 years ago have shaped our world today
- 82** How Brexit happened

WIN
SMART DIGITSOLES
WORTH
£390!
Page 95



58
Inside an atom-smasher

22
Power of the Sun



48
Antidote animals

MEET THIS ISSUE'S EXPERTS...



James Horton
Former **HIW** member James is a biochemist and biotechnologist. He is currently doing a PhD in machine learning and evolutionary theory.



Jo Stass
Jo has been a writer and editor for over six years. She is particularly interested in the natural world and technological innovations.



Jodie Tyley
The former Editor of **HIW** and **All About History** has tackled many topics in her career, from science fiction to science fact, and Henry VIII to honey badgers.



Jonathan O'Callaghan
With a background in astrophysics, former **HIW** and **All About Space** journalist Jonathan enjoys delving into the wonders of space.



Laura Mears
Biomedical scientist Laura escaped the lab to write about science and is now working towards her PhD in computational evolution.



Stephen Ashby
Stephen has been a writer and editor for over seven years. He is endlessly intrigued by technology and Earth science.



Steve Wright
Steve has worked as an editor on many publications. He enjoys looking to the past, having also written for **All About History** and **History Of War**.



Tim Williamson
History Of War Editor-in-Chief Tim has a passion for all things military but studies and writes about a range of historical eras.

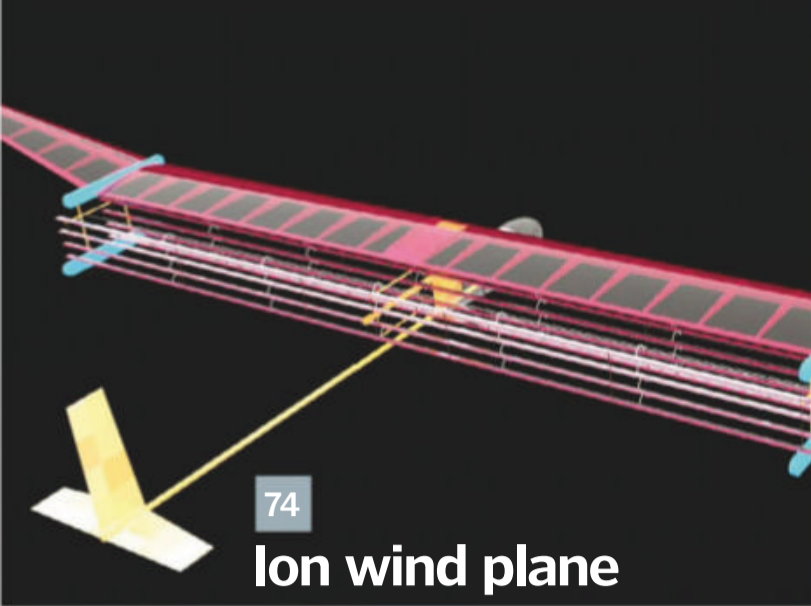

74

Ion wind plane

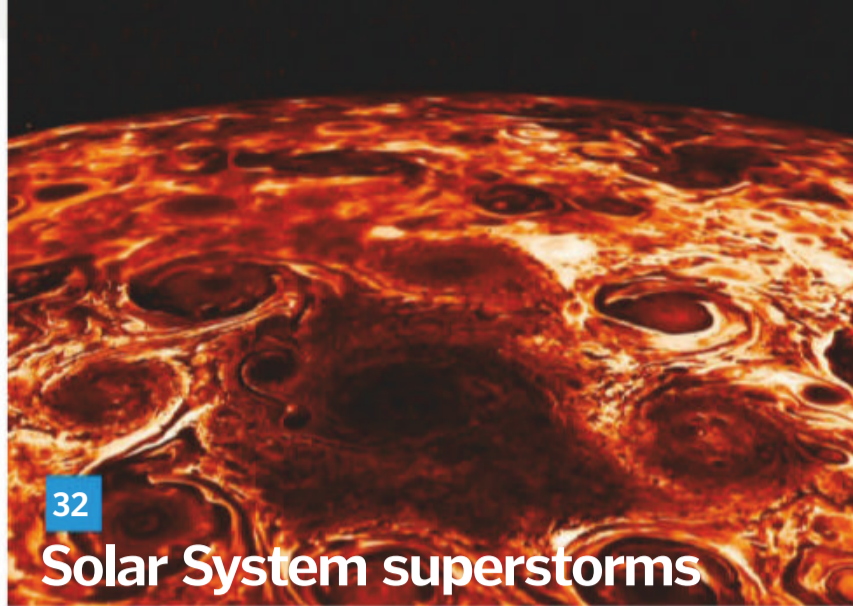

32

Solar System superstorms



70

Robot wars

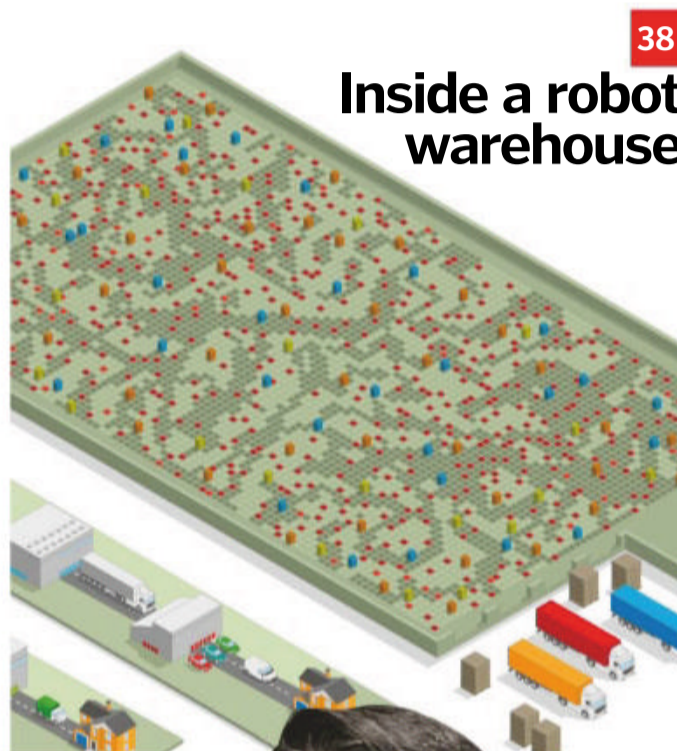

38

Inside a robot warehouse

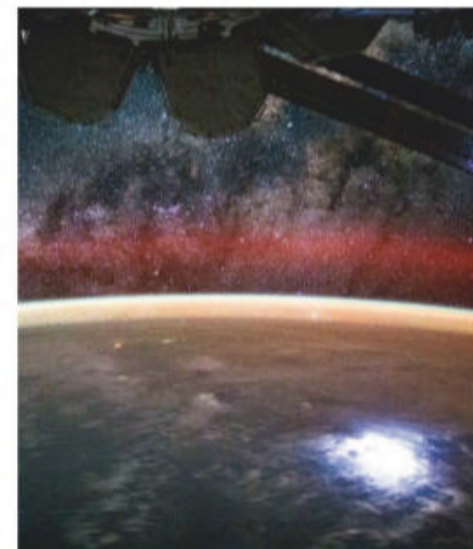

06 Global eye

Science and tech news from around the world

20 Wish list

The gadgets, games and apps we've got our eye on

83 Strategy guide

Pandemic

84 Brain dump

Your questions answered

90 Book reviews

92 Brain gym

Give your brain a workout with our puzzle pages

94 How to...

Make glowing potato goo

96 Letters

Our readers have their say

98 Fast facts

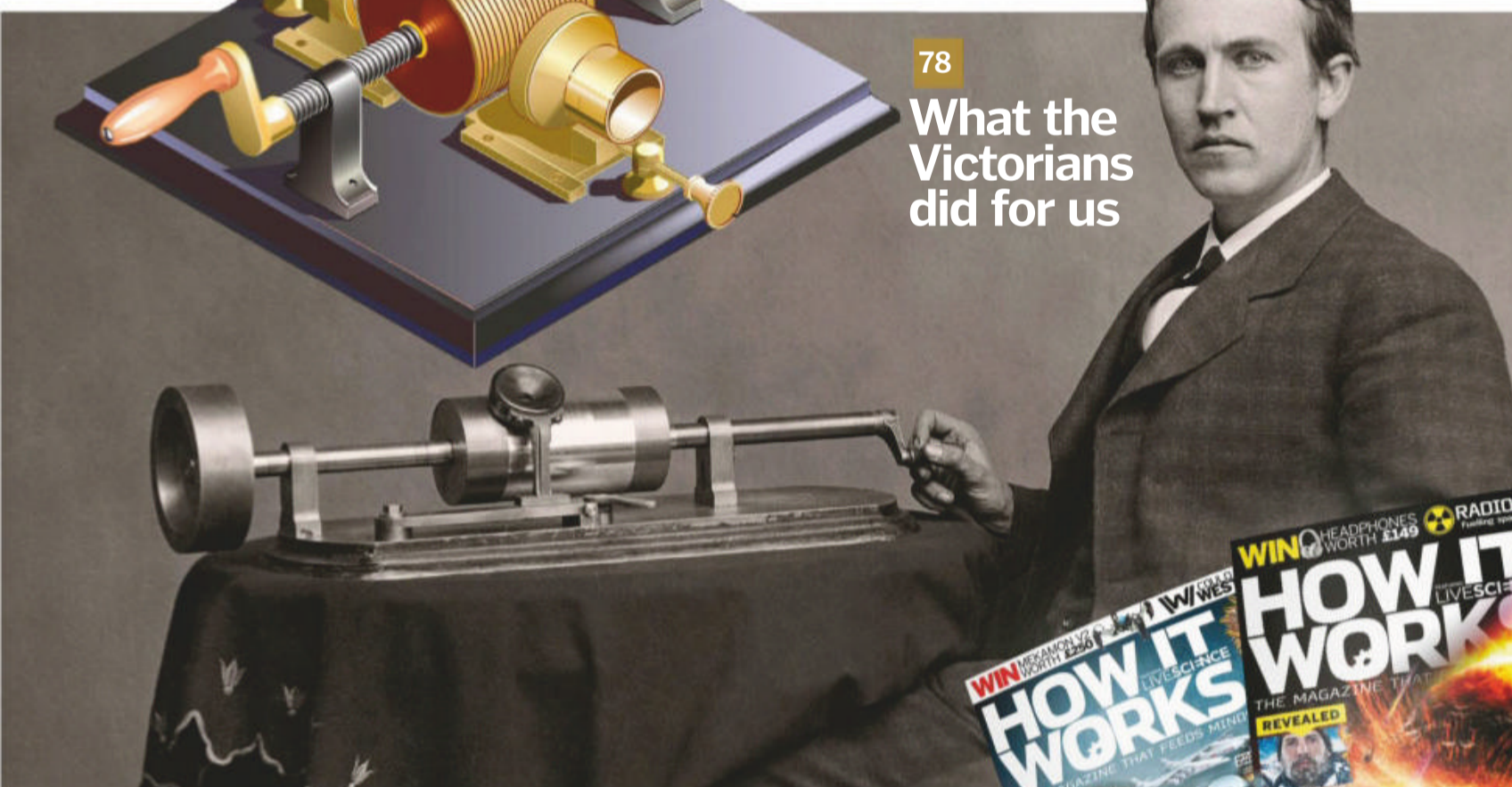

78

What the Victorians did for us



SUBSCRIBE NOW!
GO TO PAGE 30 FOR GREAT DEALS



Tom Lean

Tom is a historian of science at the British Library working on oral history projects. His first book, *Electronic Dreams*, was published in 2016.



Lee Cavendish

As *All About Space's* resident staffer, Lee is an expert on space topics but enjoys branching out into technology, too.



Jack Griffiths

Former *HIW* staffer-turned freelancer Jack works in the medical industry and loves to escape on a science & tech press event.



Amy Grisdale

Ex-*World Of Animals* staff writer Amy has an enormous breadth of experience working with animals, and specialises in environment topics.

An aerial photograph of the Great Barrier Reef, showing several large, shallow, light-colored lagoon areas separated by darker, deeper water channels. The reef extends from the top left towards the bottom right of the frame. A large, semi-transparent orange circle is overlaid on the left side of the image, containing text.

1 million tons of sludge

Australia's Great Barrier Reef is one of the seven natural wonders of the world, comprised of over 3,000 individual coral reef systems, home to an incredible range of marine life, and is the only living thing that's visible from space. Unfortunately, the Great Barrier Reef is under threat from climate change, as well as the crown-of-thorns starfish that feeds on the coral itself. More recently, a loophole in Australian law means that a nearby port will be licensed to dump 1 million tons of toxic sludge onto the reef.







Deadly radiation's pretty flower

In a secret US facility, a NACA (National Advisory Committee for Aeronautics) physicist studies the effects of alpha rays from radioactive polonium in a cloud chamber - a sealed container holding saturated vapour. The deadly blast of alpha particles creates a flower pattern at the centre of the cloud chamber.

Until the early 1960s, scientists were focused on creating safe nuclear propulsion for use in future aircraft, before the programme was abandoned. In 1958 NACA became NASA and the US began to focus on travelling beyond the sphere of our own planet.



Watching weather from space

High above the atmosphere, the International Space Station's latest experiment observes an orange airglow curving around the sphere of Earth. NASA has also greenlit the Atmospheric Waves Experiment (AWE), a mission slated for August 2022 that will attach to the outside of the ISS and observe the space weather system around our planet. It will investigate how the interaction between Earth's weather systems and solar wind affects the upper atmosphere and can interfere with satellite communications.



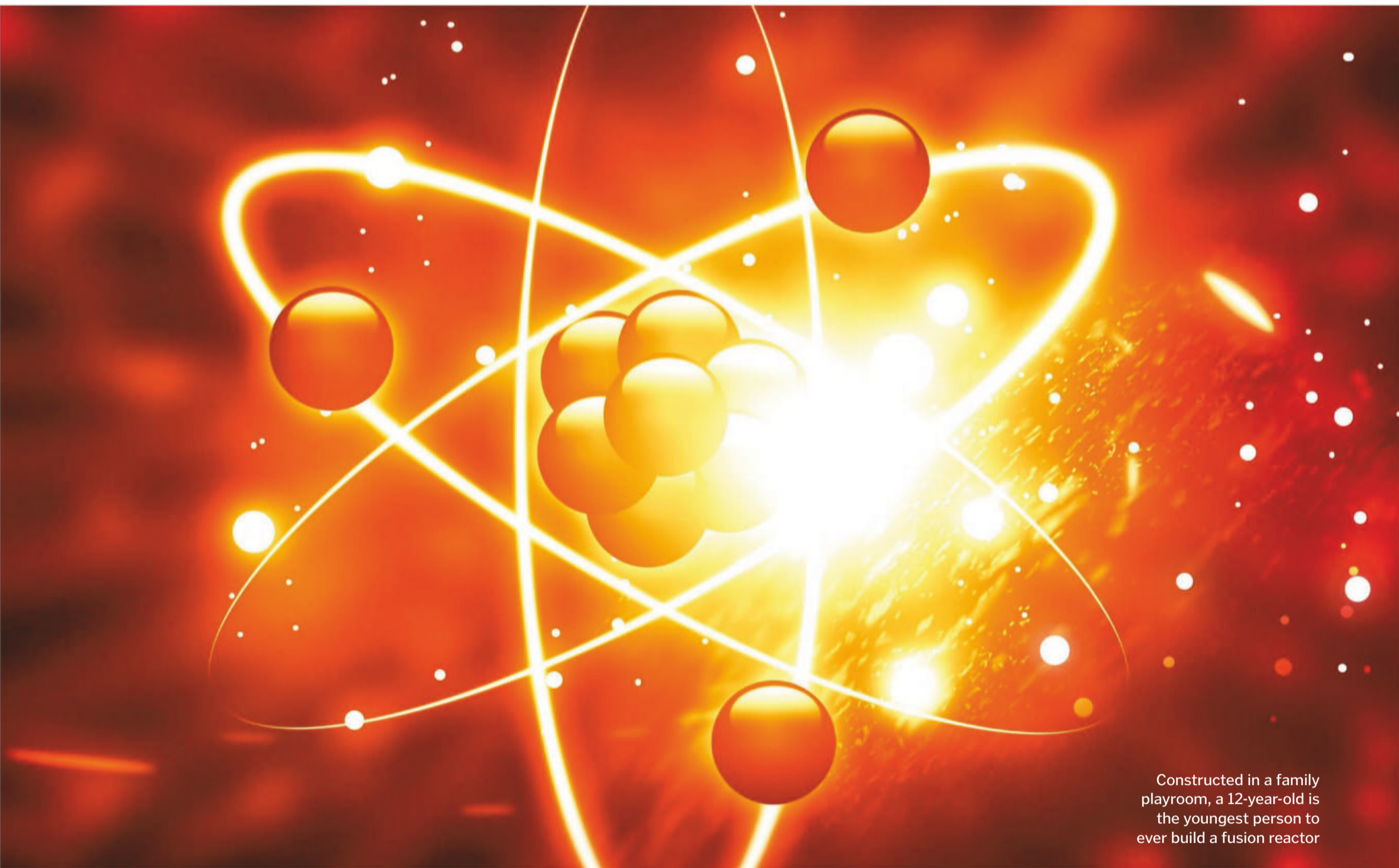

Constructed in a family playroom, a 12-year-old is the youngest person to ever build a fusion reactor

TECH

12-year-old builds fusion reactor

Words by **Rafi Letzter**

A 12-year-old child from Tennessee created a successful nuclear reaction in his family's playroom in January 2018, according *The Guardian*. That makes him the youngest known person to have done so. The Open Source Fusor Research Consortium (a group of nuclear hobbyists) recognised Jackson Oswald's achievement on 2 February, according to a report by commercial appeal, a *USA Today* affiliate. Oswald, now 14, built a machine that generates a plasma in which nuclear fusion occurs – which doesn't involve splitting an atom, but rather crushing atoms together to form heavier ones.

So to answer the obvious question: yes, nuclear reactions are things you can do at home. **Live**

Science has reported previously on nuclear startups that have started as hobbyist projects. And there are more people who make reactors purely for the fun of it. And these efforts almost always involve fusion, rather than fission. Fission requires very heavy, tightly controlled substances like uranium, whereas fusion typically involves the ultralight isotopes of hydrogen, such as deuterium, which are easier to acquire. When two light atoms fuse, the resulting 'heavier atom' is a bit lighter than the two that formed it, resulting in extra mass that gets released as energy. Achieving fusion at home doesn't mean that Oswald (or any other hobbyist) has built a nuclear reactor that could

actually generate more power than it takes to turn on. That's a trick no one, not even the Department of Energy, has yet managed to accomplish. And hobbyist reactors like this, while they do produce some radiation, produce fusion on far too tiny a scale to be seriously dangerous to anyone that isn't in their immediate vicinity.

Oswald's device also couldn't be repurposed as a bomb. That said, Fusor.net's FAQs warns that improperly shielded fusion reactions can be 'deadly'. The basic principle of fusors like this is that they use magnets to suspend isotopes of hydrogen gas in a vacuum, then pump a ton of electricity in to super-heat it until the atoms start to fuse into helium. To prove that fusion has occurred, Oswald needed to show that neutrons (which get released during the process of deuterium fusion) had been produced. *The Guardian* reported that Oswald's reactor required 50,000 volts of electricity and involved around £7,700 (\$10,000) of equipment.

The Wallace's giant bee, *Megachile pluto*, first became known to science in 1858 and is about four times larger than a European honeybee

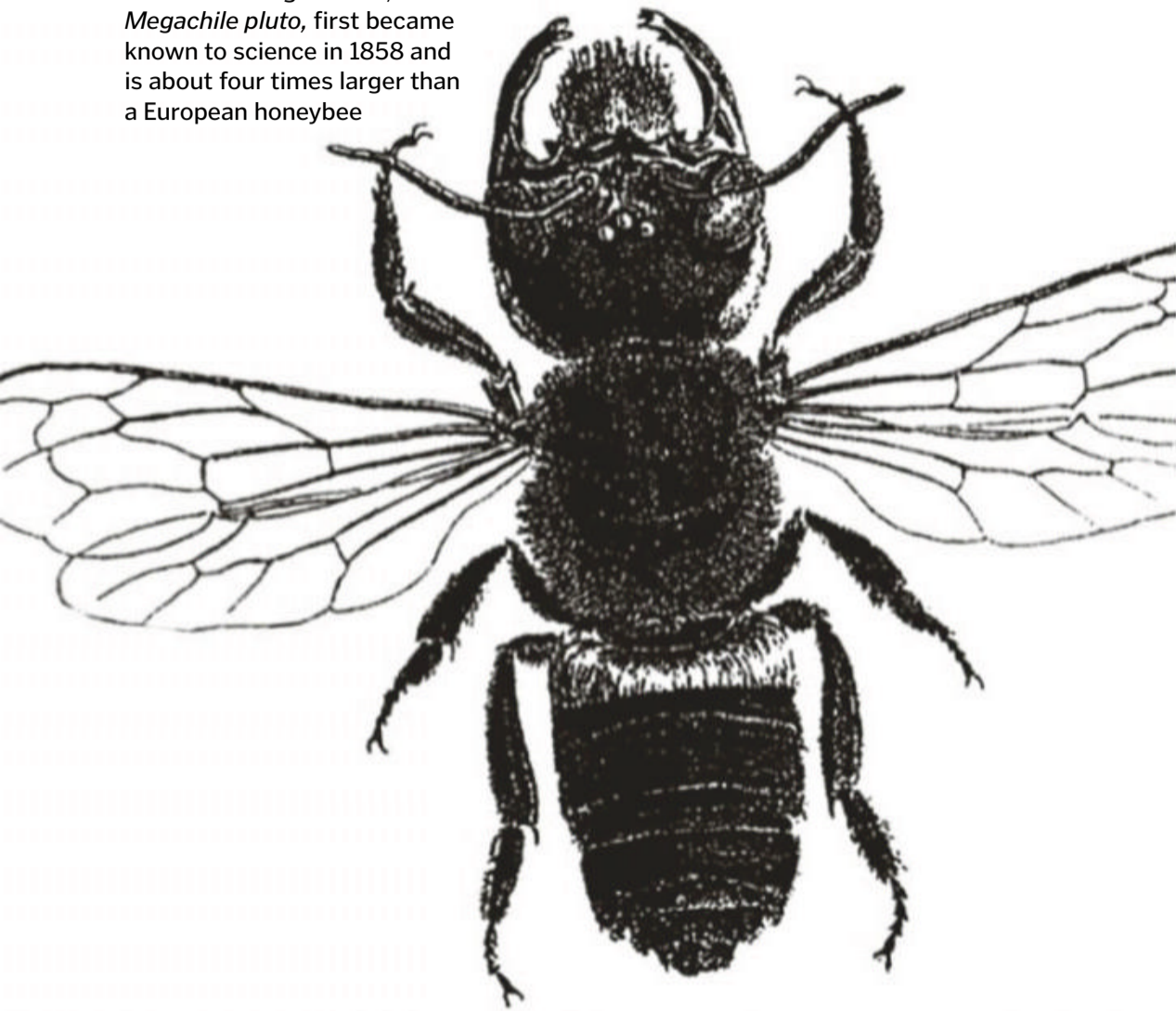

ANIMALS

Giant bee rises from extinction

Words by Mindy Weisberger

You'd think that the world's biggest bee would be hard to lose track of. But Wallace's giant bee, an Indonesian species with a 6.4-centimetre wingspan, was last seen by researchers in 1981 and was feared to be extinct. However, scientists finally spotted the rare bee in January, in the Indonesian province of North Maluku on the Maluku Islands. They detected a solitary female bee after investigating the region for five days, and a photographer captured the first-ever images of a living Wallace's giant bee (*Megachile pluto*) at the insect's nest in an active termite mound. Little is known about these elusive insects' habits. Adam Messer, a researcher with the Department of Entomology at the University of Georgia, wrote in a study published in the *Journal of the Kansas Entomological Society* in 1984 that the bees' dark-coloured bodies measure about 3.5 centimetre in length, about as long as a human thumb, and they build communal nests on termite dwellings in trees. Messer was the last scientist to document the supersize bees in the wild, until now.

PLANET EARTH

Huge iceberg to break away from Antarctica

Words by Mindy Weisberger

Cracks are growing in two directions across the Brunt Ice Shelf on the northern coast of Antarctica. The fracturing ice shelf is poised to release an iceberg about twice the size of New York City. The future of the rest of the ice shelf isn't looking too promising, either. On 20 February, the NASA Earth Observatory shared images of the ice shelf, comparing a satellite view from 23 January 2019 to another image taken on 30 January 1986. In the 2019 photo, a long fracture can be seen meandering south to north and spanning most of the shelf. Another rift, dubbed 'the Halloween crack' after its appearance in October 2016, extends from west to east along the top of the image. But the northward-travelling crack is of greater concern, as it is currently lengthening by up to four



Antarctica's Brunt Ice Shelf could soon release a giant iceberg

kilometres each year, Earth Observatory said. That fracture has just a few miles to go before it reaches the Halloween crack. Once that happens, an iceberg with an area of at least 1,700 square kilometres (660 square miles) will be lost from the ice shelf, more than twice the area of New York City's five

boroughs and the largest iceberg to separate from Brunt Ice Shelf since 1915, according to Earth Observatory. Depending on where the cracks merge, the stability of the entire shelf could be jeopardised, Joe MacGregor, a glaciologist at NASA's Goddard Space Flight Center, told Earth Observatory.

HEALTH

Stroke recovery linked to genetics

Words by Yasemin Saplakoglu

People without a certain gene may recover better from strokes and other traumatic brain injuries than people with the gene, a new study suggests. The gene, called CCR5, is the same gene at the centre of the recent CRISPR babies controversy, in which a Chinese scientist edited the gene out of two embryos to make babies who were resistant to HIV. People who don't have the CCR5 gene do show resistance to HIV, and the HIV drug called Maraviroc works by blocking the CCR5 receptor.

In the recent study, published in the journal *Cell*, researchers found that when they gave Maraviroc to mice to block their CCR5 receptors, the mice had increased control of their gait and their limbs. Even though the mice didn't experience stroke, the findings could shed light on the disease because people who've had a stroke may experience difficulty moving and controlling parts of their body.

But just because something has an effect in animals doesn't mean it will have the exact same effect in humans. So, to see how the CCR5 gene might play a role in humans and stroke recovery, the researchers collaborated with Israeli scientists at Tel Aviv University who were already tracking the recoveries of nearly 450 patients who had experienced a mild or moderate stroke. As suspected, the researchers found that patients who lacked the gene seemed to be recovering from strokes better, both physically, in terms of controlling their movement, and mentally, with improvements in memory, verbal function and attention, compared with patients with the gene.

And though an absence of CCR5 may seem like a good thing, the gene could confer some benefits, said senior author Dr. Thomas Carmichael, a professor of neurology at the University of California. Past research, for example, has suggested that it plays an important role in stopping the formation of memories. Memories form when groups of brain cells link up following a stimulus. To stop memory formation, CCR5 tells that group of cells not to link up with a certain stimulus. If you walk into your kitchen and crack an egg in a frying pan, "you want to remember that you've done that," said Carmichael. But you don't want that memory to also link up with the loud noise that just came from the garden. That's where CCR5 is thought to come in.

Those without the CCR5 gene may recover from a stroke better than those that do have the gene

各位会员：

我们推出杂志众筹订阅的目的是为了方便大家，旨在帮助大家节约订阅成本，节省寻找时间。杂志仅供自己阅读学习，禁止任何形式的分享传播！

现作以下说明：

1、杂志众筹 VIP 目前只通过个人如下 12 个微信号进行：

微信号 1: book408

微信号 2: book608

微信号 3: book208

微信号 4: book308

微信号 5: book4008

微信号 6: book4728

微信号 7: book361

微信号 8: book362

微信号 9: book599

微信号 10: book7749

微信号 11: book8848

微信号 12: MeijiEnglish

其他任何途径（淘宝、微店、QQ、微博或其他任意微信号等）**都属于假冒**，本人没有淘宝和微店，因为电子类读物做淘宝和微店很容易被封店处罚，原因你懂的。据观察所知，此类店铺少则数天，多则半年就会被查封。这也是为什么淘宝上几乎搜不到电子版外刊的原因，即使能搜到，也是刚开的寥寥数家，三五个宝贝而已，已经在被封的路上。我们现在没有淘宝，以后也不会有。

2、如果你是通过上述 12 个微信号之一加入 VIP 的，首先恭喜你选择了正式途径！其次，**VIP 会员禁止再添加上述我的其他微信号，如有同时添加上述两个甚至两个以上微信号的，一经发现，立即取消会员资格！**（之前无意添加上述两个或两个以上微信号的会员请主动告知，近期正在清查重复好友，请注意）

3、如果你是通过其他任何收费途径获取到该杂志或该网盘分享的，很遗憾你误选择了李鬼。可能在一段时间内你获得的权益和其他 VIP 会员相同（其实更新速度根本跟不上我们，也更不会有我们提供的大量福利），但是必定不能长久。我们近期正在利用深度路由追踪技术和网络云盘分享的蚁群算法清查假冒和倒卖行为，一经查出即取消所有权限。**如果你是从假冒和倒卖者那里获取到的 VIP 权限，请尽快联系你的无良卖家申请退款，不要轻信这种道德素质低下人的更新保证，他们随时都会消失，请大家尽快发起维权。也请联系我们，进行确认后，我们会妥善把你注册为正式 VIP 会员，以保障自己的正当权益。**

4、如已是 **VIP 会员**，遇到网盘分享链接失效或其他任何问题，请联系当时参与众筹的微信号，禁止添加其他微信号，禁止！后果参看第 2 条说明。

5、再次强调我们的众筹内容是 100 多种英文原版外刊和 30 多种中文杂志持续永久更新，一次性付费 188 元，即可终身订阅所有杂志，享受所有福利。众筹目前已经六年。如果你非 VIP 会员，无意中看到此说明，并对我们的杂志众筹 VIP 有兴趣，请添加特别**微信号 1295512531** 咨询办理。

祝大家阅读愉快！

STRANGE NEWS

Ancient mummy decapitated beneath Irish church

Words by **Brandon Specktor**

The head of an 800-year-old mummy known as 'The Crusader' has been lopped off and stolen from its crypt below St. Michan's Church in Dublin. According to a statement issued by the Church of Ireland, vandals are believed to have broken into the church's underground vaults last month, where they 'desecrated' the bodies of several mummies interred there. St. Michan's staff discovered the damage on 25 February 2019. In addition to beheading the mummy known as 'The Crusader' and flipping it over in its coffin, the vandals also damaged the 400-year-old remains of a mummy known as 'The Nun', the church reported. St. Michan's Church was founded in 1095, but the present church building was completed in 1685,



Someone recently decapitated one of the church's more famous mummies, known as The Crusader, and ran off with its head

according to the church's website. The crypts below St. Michan's hold many mummies, though their history is not fully known. According to the church, the bodies of the men and women entombed there slowly mummified over time thanks to the basement's naturally dry atmosphere, which is partially due to limestone bricks sucking moisture out of the air. This

dryness has also caused some of the mummies' caskets to disintegrate, exposing the corpses inside to public view. The Crusader and The Nun were among the crypt's most visible and most visited mummies. According to Atlas Obscura, church officials once encouraged visitors to shake The Crusader's outstretched hand, a practice that ended in 2017.



President Donald Trump signs Space Policy Directive-4 in the Oval Office of the White House on 19 February 2019

SPACE

Trump launches Space Force

Words by **Mike Wall**

The Space Force just took a big step from sci-fi-sounding dream toward reality. President Donald Trump has signed Space Policy Directive-4 (SPD-4), ordering the Pentagon to establish the Space Force as the sixth branch of the United States military, to go along with the army, navy, air force, marines and coast guard. But the Space Force still has a big hoop to jump through: Congress must approve the creation of any new military branch. The main goal of the Space Force is to secure and extend American dominance of the space domain, Trump and other White House officials have said. Such reasoning has drawn opposition from various quarters. "President Trump has called space a new warfighting domain. Space is important to militaries, that's true, but it is only a small piece of what happens up there," Laura Grego, a senior scientist in the Union of Concerned Scientists' Global Security program, said in a statement.

© Getty/Alamy

HISTORY

5,600-year-old skull fished from Thames

Words by **Brandon Specktor**

Humans have lived alongside England's River Thames for thousands of years, and they've left some interesting things behind in its muddy waters: wooden clubs for bashing in heads, a toilet that fits three bums at once and, sometimes, even bits of human skulls. The Museum of London has put one such skull fragment on display. According to a statement from the museum, the fractured frontal skull bone belonged to an adult man who lived sometime around 3600 BCE, making this Neolithic skull chunk one of the oldest human specimens ever pulled out of the Thames. According to the museum, the specimen was initially discovered near the southern shores of the Thames by a 'mudlarker' - a person who digs through the river mud in search of valuables. (Mudlarkers have made scavenging the Thames their business for hundreds of years;

in fact, the 500-year-old skeleton of a dead mudlarker wearing thigh-high leather boots was recently exhumed from the river.) Excited, or perhaps terrified, by the shattered chunk of human cranium he found by the river, the lucky mudlarker did what any of us would have done: he promptly called the police. "Upon reports of a human skull fragment having been found along the Thames foreshore, Detectives from South West CID (criminal investigation department) attended the scene," DC Matt Morse from the London Metropolitan Police said in the statement. "Not knowing how old this fragment was, a full and thorough investigation took place, including further, detailed searches of the foreshore." For better or worse, the police didn't turn up any more bones. Using radiocarbon dating, which measures levels of different versions of

radioactive carbon atoms, they at least learned that the fragment wasn't involved in any recent criminal activity - the skull bone came from a male over the age of 18 who lived roughly 5,600 years ago. You can now see the bone for yourself at the Museum of London in London, where it will sit alongside other Neolithic artefacts carried through time by the mad, muddy River Thames.

"The fractured frontal skull bone belonged to an adult man who lived sometime around 3600 BCE"



This human skull fragment was retrieved from the River Thames in London. It is roughly 5,600 years old



Radioactive material found in a cremation chamber after the cremation of a person injected with drug intended to battle cancer

HEALTH

Radiation spreads in cremation chamber

Words by **Rafi Letzter**

Doctors in Arizona injected a 69-year-old man with a drug designed to shrink tumours growing in his body. The drug was radioactive. Sadly, the medicine didn't save him, and, two days later, he died. Five days after that, his body was cremated, spreading radioactive particles all over the crematorium. That cremation, which occurred without the knowledge of the doctors who had injected the radioactive material into the man's body, posed a danger to crematory workers. And researchers say it's a problem that may be more common than anyone has yet realised. In a short paper recently published in *The Journal of the American Medical Association* (JAMA), researchers reported the results of a thorough investigation of the crematorium and the worker who dealt with the radioactive remains. The researchers found significant radiation left

on the crematory equipment, including the 'oven, vacuum filter and bone crusher'. A sample of the crematorium worker's urine also turned up trace amounts of radioactive material. The researchers wrote that the worker probably didn't receive a dangerous dose of radiation, but they added that the questions of how often radioactive bodies get incinerated or how frequently crematory workers are exposed are still unanswered. The good news is, the researchers wrote, that lutetium-177 (the radioactive element in the injection) has a short range and short half-life. That means that any dangerous effects wouldn't have spread far or lasted very long. But in the future, the researchers argued, safety protocols for radioactive medicines should take into account the possibility of death and cremation so as to protect the public.

www.howitworksdaily.com

TECH

False nuclear missile alert sends Hawaii into chaos

Words by **Jeanna Bryner**

If you were told to take cover because of an incoming nuclear ballistic missile, would you seriously know what to do? Or would you run around frantically or curl up in a foetal position? Many people in Hawaii faced that very question on 13 January 2018. That morning, at 8.07am local time, the Hawaii Emergency Management Agency sent out an alert advising residents to seek shelter from an incoming ballistic missile. Unbeknown to just about everyone at the time, however, the alert was a false alarm. It was accidentally sent out during a shift change, and the incoming operator didn't realise that the alert was part of a preparedness drill. Though it was an error, the alert revealed that Americans aren't prepared for an attack and that public health officials need to improve their messaging, according to the Centers for Disease Control and Prevention (CDC); the CDC came to their conclusion after reviewing relevant Twitter responses posted during the 38-minute period before the alert was retracted and the 38 minutes afterward. Those tweets revealed a lot of confusion and fear, the researchers said, after analysing 5,880 posts. The report not only revealed some holes in Hawaii's dissemination process for such alerts and 'all clear' messages, but also showed that the message lacked instructions.



A false alert of an incoming missile caused mass confusion on social media

© Alamy/Getty; Museum of London

PLANET EARTH

'Firefall' flares at Yosemite park

Words by **Brandon Specktor**

In late February, a band of flaming orange light poured down the face of Yosemite National Park's most iconic cliffside. It wasn't an impromptu eruption of magma. It wasn't hot at all. It was the latest example of the annual phenomenon known as a 'firefall', a sublime trick of winter light that mixes melting snow with the setting Sun. Yosemite's firefall occurs almost every year around mid-February to the end of the month, when the snowpack atop the park's El Capitan rock formation begins to melt and flow down the cliffside, forming a seasonal waterfall known as Horsetail Fall. As the meltwater plunges 457 metres to the ground, the setting Sun throws its light against the falls. If the sky is clear and the Sun is positioned precisely in the western sky, that setting sunlight paints the water with fiery orange, yellow and pink light.

A stunning firefall returned once again to Yosemite's iconic El Capitan rockface

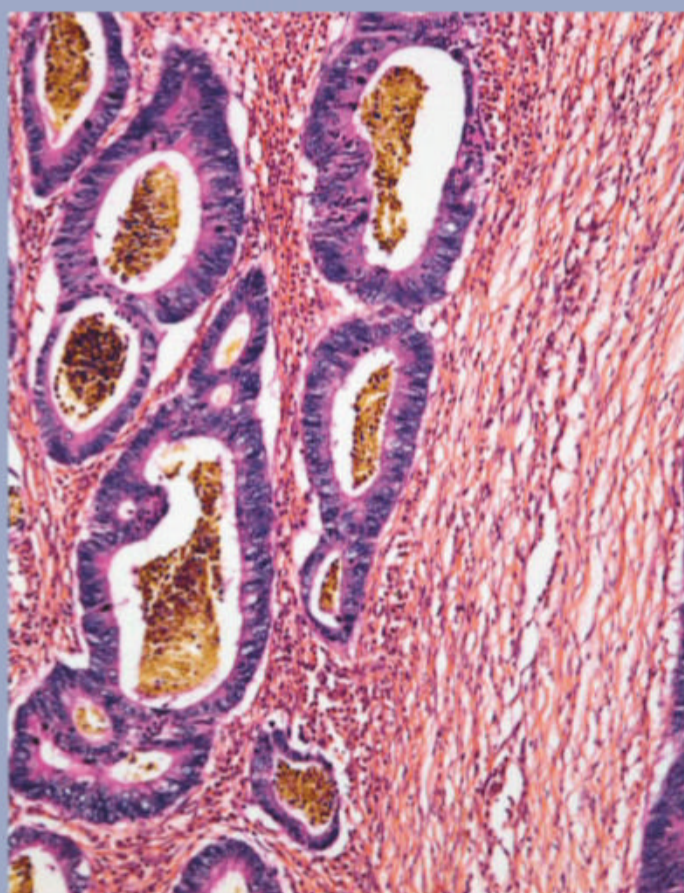

New at-home testing could be as effective at detecting colorectal cancer as colonoscopies

HEALTH

Cancer home test kits are effective

Words by **Cari Nierenberg**

An at-home screening test for colorectal cancer may be as good an option as a colonoscopy, a new review study finds. The FIT, or faecal immunochemical test, works by determining whether there is blood in a person's stool sample that is not visible to the naked eye. The study found that the FIT test had a sensitivity of a 75 to 80 per cent, meaning it identified cancer in 75 to 80 per cent of individuals who had the disease, said lead author Dr. Thomas Imperiale, a gastroenterologist at the Indiana University School of Medicine and Regenstrief Institute in Indianapolis. To compare, a colonoscopy

has a sensitivity of 95 percent. These findings suggest that a FIT test done every year is a very acceptable alternative to a colonoscopy for people at average risk of colorectal cancer, Imperiale told *Live Science*. The FIT test is done by placing a paper sling in the toilet seat to catch a stool sample before it hits the bowl, Imperiale said. Then, a brush is used to obtain a smaller stool sample, which is sent to a lab for analysis. Results are then sent to physicians, who communicate the findings to their patients. If a patient has a positive result, they would need to have follow-up testing in the form of a colonoscopy.

SPACE

'Snowflake-pancake' asteroid gets a close-up

Words by **Mike Wall**

The best-ever photos of Ultima Thule have made it down to Earth, and they heighten the intrigue about the frigid and faraway world. On New Year's Day 2019, NASA's New Horizons spacecraft zoomed past the 34-kilometre Ultima Thule, setting a record for the most distant planetary encounter in history. Ultima lies about 1.6 billion kilometres beyond Pluto, which New Horizons flew by in July 2015. New Horizons has been beaming flyby data and imagery home to its handlers ever since, and will continue to do so for approximately another 18 months. The early returns have been spectacular, revealing Ultima Thule to be a weird, snowman-pancake hybrid with

mysterious features, such as a bright 'collar' where the body's two lobes meet. And now we have our best look yet. New flyby photos show Ultima in even more detail, capturing bright ring-like features and dark pits, whose origins remain mysterious. The newly released images boast a resolution of about 33 metres per pixel. They're the highest-resolution pictures New Horizons has taken, and may ever take during its operational life, mission team members said. The photos were captured just 6.5 minutes before the craft's closest approach on 1 January. At the time, New Horizons was 6,628 kilometres from Ultima Thule and 6.6 billion kilometres from Earth, mission team members said. There

was no guarantee we'd ever see Ultima Thule, whose official name is 2014 MU69, in this dazzling light. Capturing the newly released images was a 'stretch goal' that demanded a precise square-up of Ultima in the narrow field of view of New Horizons' telescopic camera. "Getting these images required us to know precisely where both tiny Ultima and New Horizons were – moment by moment – as they passed one another at over 32,000 mph [51,500 kph] in the dim light of the Kuiper Belt, a billion miles beyond Pluto. This was a much tougher observation than anything we had attempted in our 2015 Pluto flyby," New Horizons principal investigator Alan Stern, of SwRI, said in the same statement.

This photo of Ultima Thule is a processed composite combining nine individual images taken by NASA's New Horizons spacecraft

For more
of the latest
stories head to
livescience.com

WISH LIST

The latest health and fitness tech

Raptor AR Smartglasses

■ Price: From £649 / approx. \$855
www.eversight.com

With a unique combination of augmented reality and cycling, the Raptor smartglasses are able to show the wearer's stats without them taking an eye off the road. Keep track of your heart rate, distance and speed through Eversight's BEAM projection technology. Not only can you monitor your progress while on route, but riders can also record video and take stills of their surroundings. With eight hours of battery life, Raptor is perfect for triathlon training or for simply capturing a scenic cycle.

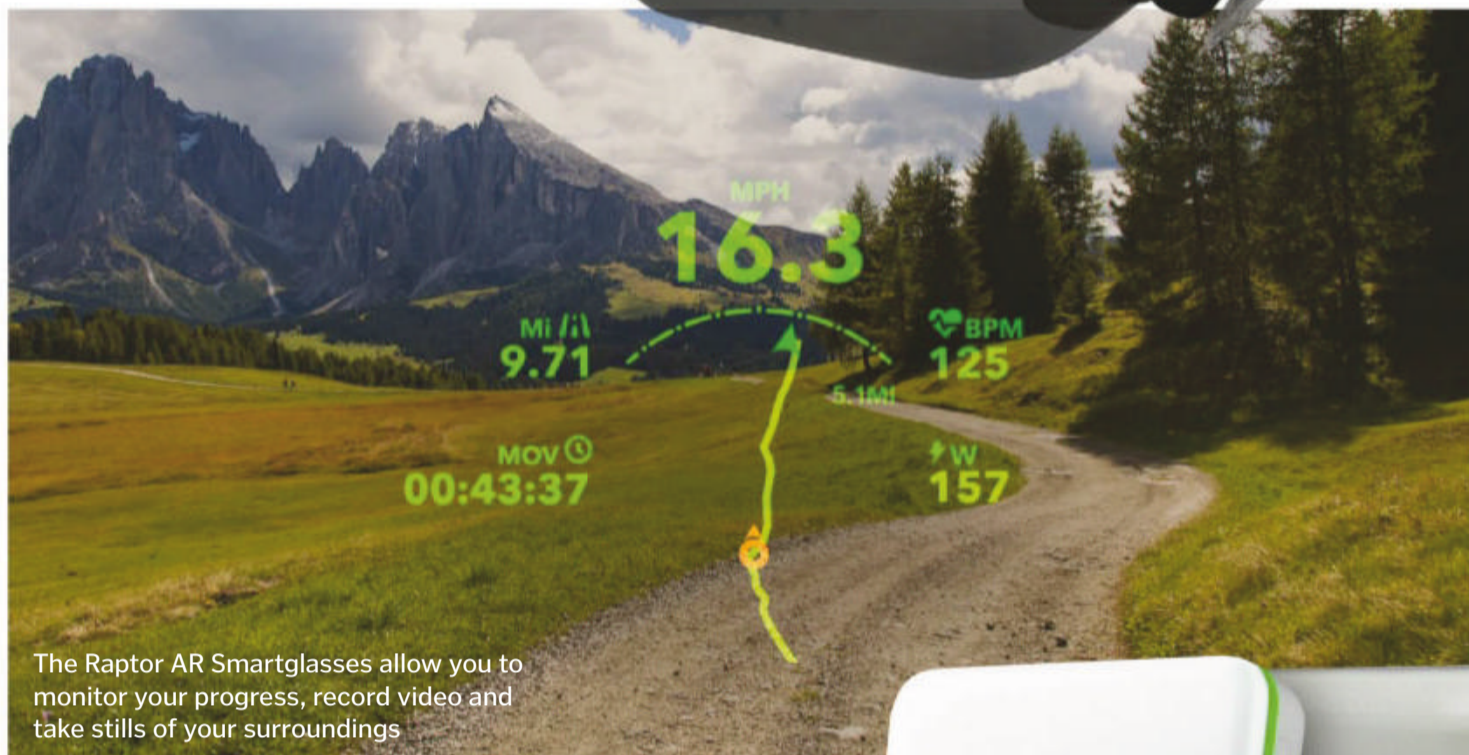

The Raptor AR Smartglasses allow you to monitor your progress, record video and take stills of your surroundings



Digitsole Run Profiler

■ Price: approx. £85 / approx. \$115
www.digitsole.com

The first of its kind, Digitsole is a smart trainer insole perfect for runners (or cyclists) looking for feedback to better understand their movements on a run. Bluetooth connected, the accompanying app records a runner's speed, pace and stride with the aid of the in-built sensors. Not just a monitoring tool, the Digitsole can also offer advice on future runs and even identify when a runner is experiencing fatigue.

Skulpt

■ Price: approx. £75 / \$99
www.skulpt.me

Often we measure our fitness success based on our waistline or the results of a weighing scale, however, the Skulpt scanner is taking a different approach to monitoring our fitness success. Using electrical impulses, Skulpt is able to measure body fat and muscle quality across the body to provide a body breakdown of your overall fitness.



KuaiFit K Headphones

■ Price: £49.99 / \$49 www.kuai.fit

As well as being comfortable fitting headphones, the KuaiFit K Headphones are a great partner gadget during any physical activity. These Bluetooth-enabled, noise-cancelling wireless headphones not only play your favourite tunes at the touch of a button but also act as an in-ear coach. The KuaiFit app is filled with training programmes for you to listen to while on a run.



With the aid of an accompanying app, the Bluetooth enabled Hidrate Spark measures every sip of water taken

Hidrate Spark 2.0

■ Price: approx. £35 / \$45 www.hidratespark.com

Hydration is key while exercising, but it's easy to forget to take a sip of water during a session. The Hidrate Spark is a smart water bottle that not only glows to indicate it's time to drink but monitors your drinking habits.

With the aid of an accompanying app, the Bluetooth enabled Hidrate Spark measures every sip taken. The Hidrate app will also pair with other smart devices and even offer a suggestion for your daily water intake.

Polar M430 GPS watch

■ Price: £174.50 / \$199.95
www.polar.com

Jam-packed with a whole host of features, the Polar M430 is an excellent addition to anyone's fitness regime. As a GPS smartwatch, the M430 not only measures distance, heart rate and speed but also offers several training programmes to further your fitness. These include running programmes, heart rate testing and interval timers.



SPECIAL ITEM!

Science Museum Timeline

■ Price: £14 / approx. \$20
<https://shop.sciencemuseum.org.uk>

Answer the questions and plot your timeline using the 110 cards. Was the first electric iron invented before or after the lightbulb? But what if it was actually dated somewhere between the development of canned food and the Flying Scotsman's first journey? And was Uranus discovered around the same time as the Cat's Eye Nebula? The objective of the Science Museum Timeline game is to be the first player to play all of your cards correctly.



www.howitworksdaily.com

APPS & GAMES



Keep Yoga

■ Developer: Keep Inc.
■ Price: Free / Google Play / App Store

Keep Yoga allows you to explore the world of yoga with over 400 poses and ten session plans. Beginners and experts are welcome, and the app offers real person guidance with its video selection.

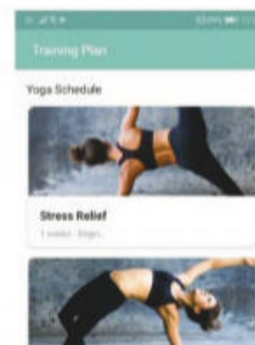

Calm

■ Developer: Calm.com Inc.
■ Price: Free / Google Play / App Store

Meditation and a good night's sleep are important for your mental health. Calm is an app designed to help you do both with guided meditation sessions, breathing programmes and sleep stories.

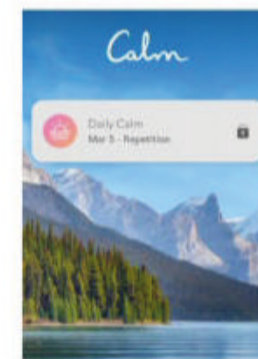

Walkr: Fitness Space Adventure

■ Developer: Fourdesire
■ Price: Free / Google Play / App Store

Exercise can sometime feel like a chore, but Walkr uses your steps to measure progress through its space-age game. Each step powers your rocket, allowing you to explore the universe.



Strava tracker

■ Developer: Strava Inc.
■ Price: Free / Google Play / App Store

Training for a triathlon? Then Strava is the app for you: this GPS tracker app not only analyses your training progress, but with its social media compatibility, you can share your routes with friends.

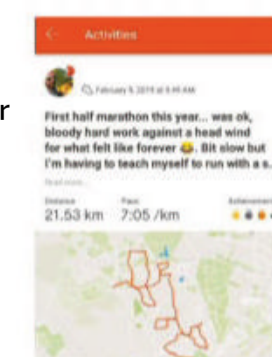



6X
6E
6Q
06L

C FRONT 90

FACE "F"

125

32

132

5"

3 1/2"

13/32 DIA.

L x 45°
32 CHAM.

5/16 DRILL, 1/4 DEEP, ANGULAR
LOCATION IMMATERIAL.
FOR DRILL FOR
POWER TAKE OFF'S
ONLY.

000Z. IN. 7/8 DIA.
03 MAX. DEPTH
RADIUS. MAX. DE
AS SHOWN

N
DIAM
PRE-SS
PITCH
DEPTH

USE RIN
WITH 00
AT 30° A

DRILL, 4 HOLE
AS SHOWN

KEYWAY (SEE CHART)
RELATION TO GEAR
TEETH & HOLES
IMMATERIAL
(UNLESS NOTED)



POWER OF THE SUN

Our star is the heartbeat that keeps Earth alive. Can we recreate this fundamental energy source on Earth?

Words by **Laura Mears**

The Sun is the powerhouse of the Solar System, and this giant fusion reactor is vital to life on Earth. Almost every organism on the planet owes its life to our nearest star. Its stellar pulse depends upon the smallest and lightest element in the universe – hydrogen – and a reaction called the proton-proton chain.

Hydrogen atoms are as simple as they come. The basic version has one positively charged proton for a nucleus, orbited by one negatively charged electron. Normally, atoms keep their distance from one another; the positive charges inside their nuclei repel, like magnets. But at the heart of the Sun, the temperature and pressure is intense. The atoms there move so quickly that they slam through the repulsive nuclear forces, colliding at high speed. When these collisions happen, the nuclei can get stuck together.

Nuclear fusion takes place in stages, starting with a collision between two

protons. When this collision happens, one proton spits out a positron (a positively charged electron) and a neutrino (an electron with no charge). With these two particles missing, one proton becomes a neutron, and the pair form a heavier isotope of hydrogen called deuterium.

The next stage happens when that deuterium hits another proton. This fusion releases a burst of gamma radiation and creates a new type of atom, a light version of helium called helium-3. Now carrying two protons and one neutron, this atom is ready for the final stage of the fusion process.

When two helium-3 atoms collide, they fuse to make an alpha particle (helium-4). This particle contains two protons and two neutrons (like a normal helium nucleus). The remaining two protons shoot away, ready to go through the cycle again.

But how does this create energy? To understand the power of the Sun, we need to

delve into the equations of one of the greatest scientists who ever lived: Albert Einstein. In his theory of special relativity, Einstein explained that mass and energy are the same, and one can become the other. His famous equation, $E = mc^2$, describes their relationship. The energy (E) of an object is equal to its mass (m) multiplied by the square of the speed of light (c). This is the relationship that powers the nuclear reactor at the heart of our star.

The helium nuclei the Sun produces have less mass than the hydrogen nuclei that made them. When the atoms slam together, a tiny proportion of their mass (less than one per cent) escapes. Less than one per cent might sound tiny, but a quick look back at Einstein's equation explains how nuclear fusion produces so much power. The speed of light is 299,792,458 metres per second, so it only takes a tiny release of mass to let out a huge amount of energy.

The Sun has been converting mass into energy for more than 4 billion years, and it's already burnt through a lot of fuel. If you looked into the core today, you'd find that around 62 per cent of the hydrogen nuclei have already fused to

become helium. However, there's a lot of hydrogen left and the process happens slowly, which is lucky for us, because almost all life on Earth depends upon the Sun for survival.

Though we don't yet know exactly how life evolved, we know that the Sun played an important role. Before life, Earth had no oxygen in its atmosphere. The air was a thick fog of carbon dioxide, methane and sulphurous gases venting out from the molten rocks. Life emerged around 3.8 billion years ago, probably in hot vents deep under the sea.

|||||
*"The Sun has
 been converting
 mass into energy
 for more than 4
 billion years"*
 |||||

The hydrogen bomb 'Ivy Mike' triggered nuclear fusion on Earth for the first time



A few types of modern microbe still live in these strange environments, including bacteria called acetogens and archaea called methanogens. They harvest chemicals from Earth's rocks, strip electrons away and use the energy to break the oxygen out of carbon dioxide.

This enables them to make organic molecules like acetate and methane, and energy-carrier molecules like ATP. The trouble with these reactions is that they don't make that much energy. For life to boom on Earth, organisms needed a better way to power their

When the Sun runs out of hydrogen it will balloon into a red dwarf

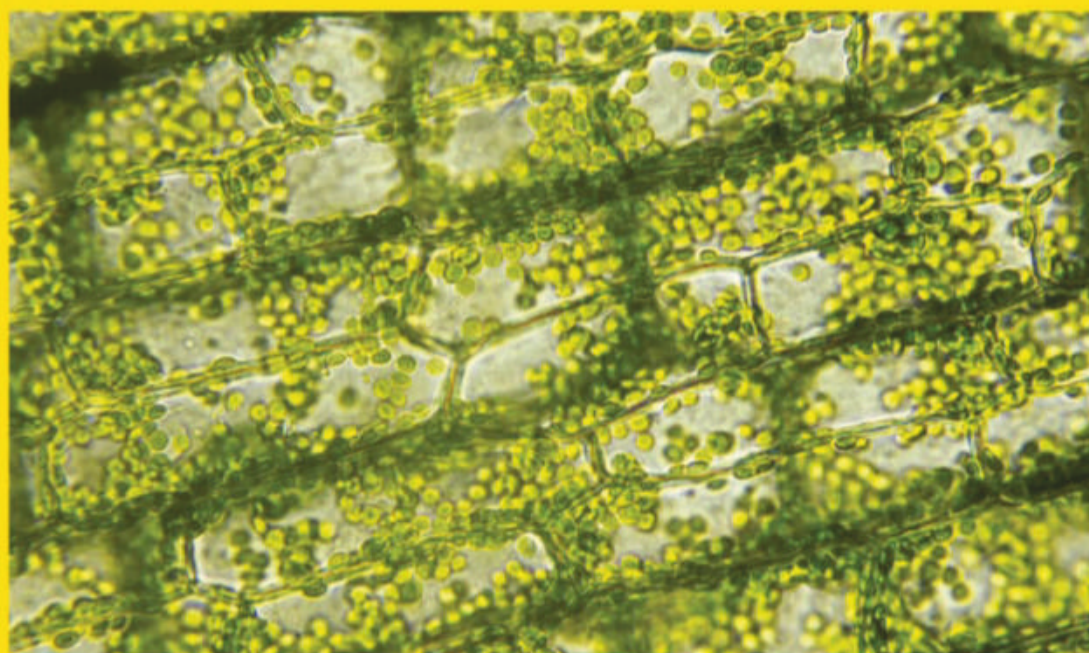
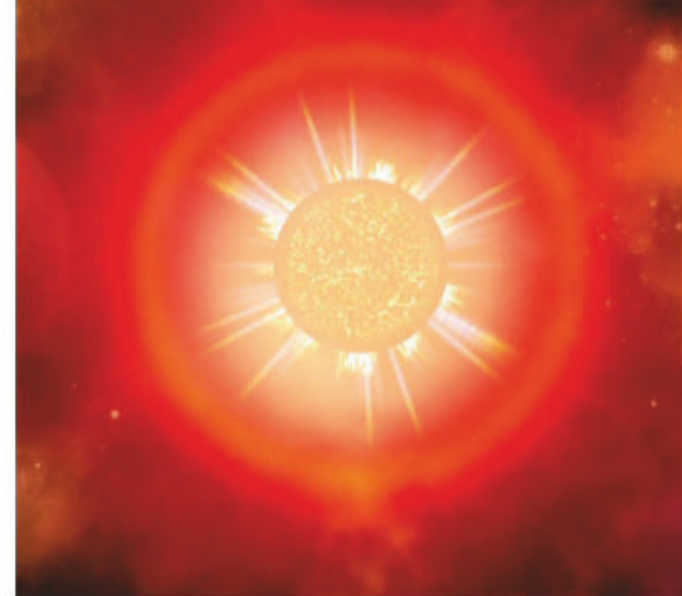

The tiny green chloroplasts that power these cells used to be free-living bacteria

Converting sunlight into food

Plants trap the Sun's power in two high-energy molecules, NADPH and ATP, before releasing it again to make sugar and oxygen. The process begins with two lower energy molecules, NADP⁺ and ADP, and two types of chlorophyll, P680 and P700.

The chlorophylls work together with other pigments to capture photons of light. P680 goes first, absorbing a photon and spitting out an electron. The electron passes into a transport chain, releasing energy as it moves from link to link. This energy powers the production of ATP.

At the end of the chain, the electrons reach P700, which absorbs its own photon and passes the electrons into a second transport chain. This time, they power the production of NADPH.

The NADPH and ATP molecules go on to power a series of chemical reactions called the Calvin cycle. The cycle combines carbon dioxide with hydrogen ions to make sugar, providing the building blocks that keep life on Earth alive.

HOW THE SUN CREATES ENERGY

Inside the Sun's nuclear reactor is a massive matter-to-energy converter

The radiative zone

Radiation ricochets around in the interior of the Sun for over 170,000 years before it finds its way out.

Thermonuclear fusion

Hydrogen atoms in the Sun's core fuse together, forming helium and releasing pulses of gamma radiation.

The convection zone

Radiation heats a layer of ionised atoms, forming a swirling pool of bubbling plasma.

Collisions

Ions in the hot plasma slam together, releasing energy as photons of light.

The core

The temperature at the heart of the Sun is 15 million degrees Celsius.

Gamma radiation

The energy released by thermonuclear fusion travels outward through the radiative zone.

The chromosphere

The red-tinged inner atmosphere of the Sun contains luminous fingers of gas bursting up from below.

The photosphere

The Sun emits a stream of energy as electromagnetic radiation (heat and light) and charged particles (solar wind).

The corona

Excess heat in the white halo around the Sun boosts the speed of charged particles, spitting them into space.

A STAR IS BORN

The experimental tokamak power plant uses magnets, vacuums and hot plasma to fuse atoms and create a synthetic Sun

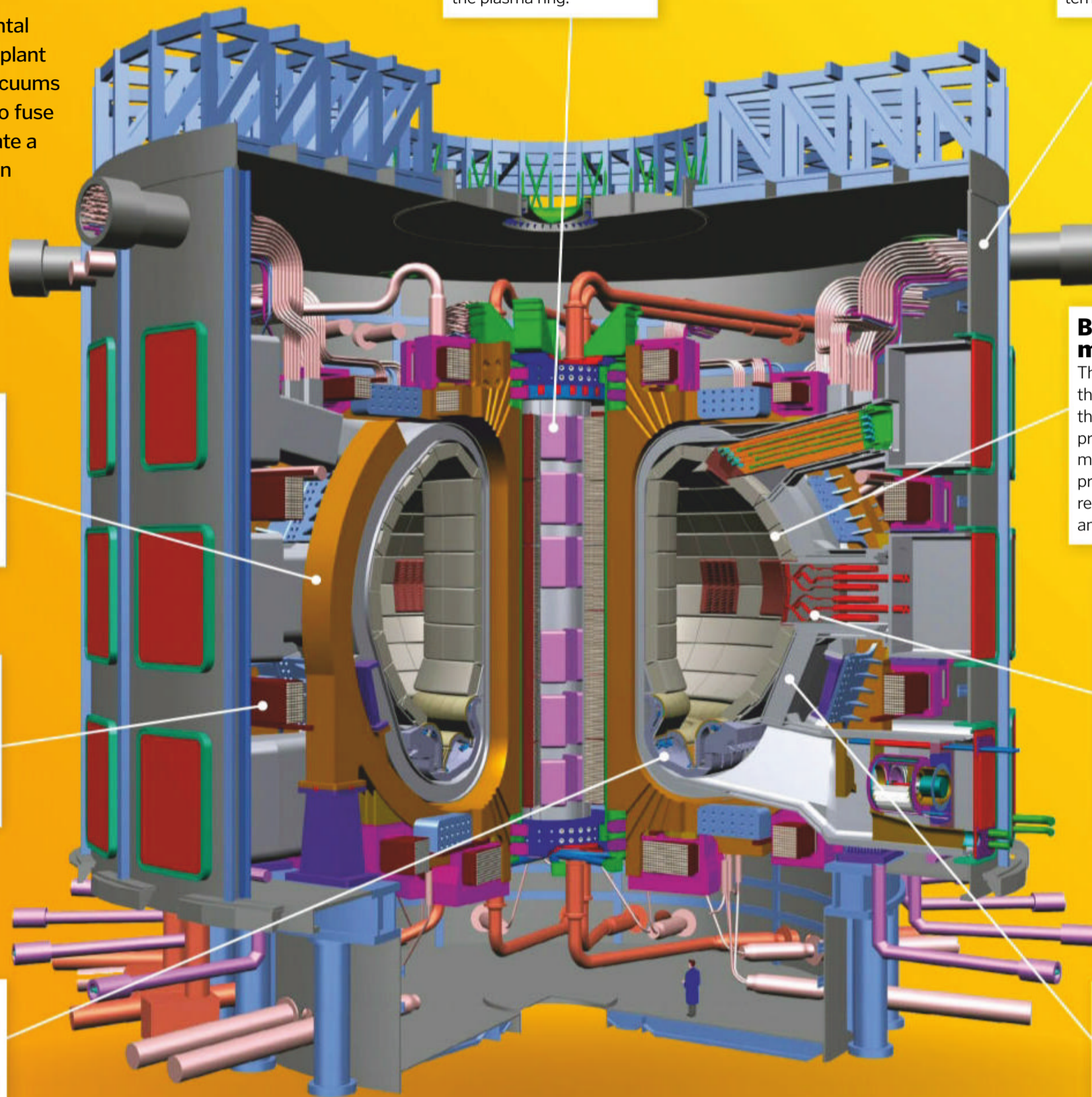

Magnetic field
When the central magnet switches on, it induces a powerful magnetic field in the plasma ring.

Insulation
A steel shell encases the system in a vacuum, keeping the temperature cool.

Doughnut magnets
Toroidal field coils keep the plasma under control by forcing it into a doughnut shape.

Blanket modules
These shields coat the inner surface of the vacuum vessel, protecting the magnets from the products of fusion reactions - heat and stray neutrons.

Plasma protection
Ring-shaped magnets keep the plasma away from the walls of the vacuum vessel.

Particle cannon
The ion cyclotron system accelerates beams of particles and fires them at the plasma, heating it up.

Divertor
The waste-disposal system sits under the vacuum chamber, removing heat and ash.

Vacuum vessel
This sealed, air-free chamber contains the ring of plasma.

Magnetic cage
A constant current through the toroidal magnets creates a doughnut-shaped magnetic field.

CREATING CURRENTS

A ring of super-hot plasma swirls at the heart of the tokamak

Plasma
In this high-energy state of matter, electrons break away from atoms, creating a soup of charged particles.

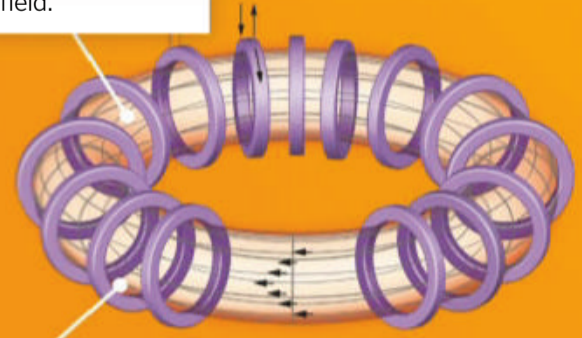

Containment
The magnetic field interacts with the charged particles in the plasma, trapping them inside the ring.

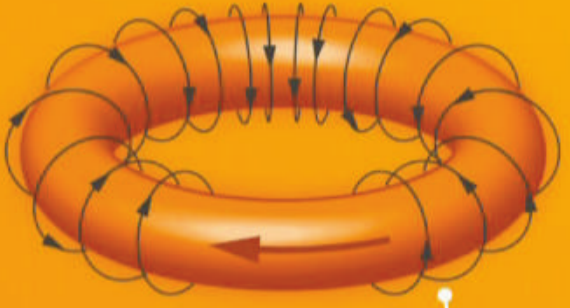

Transient fields
Pulses from the poloidal magnets induce a current in the plasma, creating magnetic fields that pass around the doughnut.

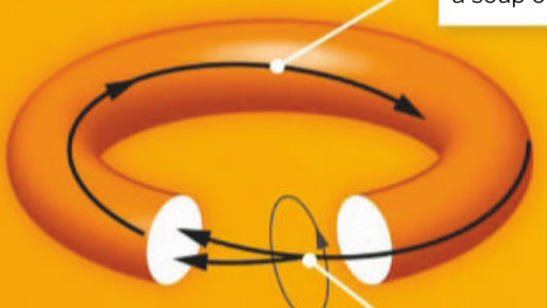

Stirring the soup
The fields from the toroidal magnets interact with the fields from the poloidal magnets, twisting the plasma current.

chemistry. Enter the phototrophs. These organisms use the energy from light to break into chemical bonds.

The most famous phototrophs are, of course, plants. Plant cells contain dozens of chloroplasts, each stuffed with discs called thylakoids. The thylakoids house molecular machines called photosystems, which contain chlorophyll pigments. These capture photons of light from the Sun, harnessing their energy.

Evolving the ability to make chlorophyll is so complicated that scientists think it happened only once. This means that every organism that uses chlorophyll must have come from the same ancestor – photosynthetic cyanobacteria that lived more than 2.15 billion years ago. These strange cells were able to make food and oxygen from light, and other cells wanted to get in on the action. Larger cells started to live alongside the bacteria, sharing their resources. The relationship became so close that the larger cells eventually absorbed the smaller ones. The two types of cell evolved together, and the bacteria lost the ability to live on their own, becoming the chloroplasts we see in plant cells today. Photosynthesis now provides the raw materials for almost every food web on the planet.

Sun-powered evolution changed Earth, but while we've been busy adapting to sunlight, the

Sun has been changing too. It's been fusing hydrogen for 4.5 billion years, and in that time it's been getting brighter. For every four hydrogen atoms that it fuses to make a helium nucleus, the mass inside its core drops. There are now far fewer atoms in the centre of the star, and this means that there are fewer particles to balance gravity pulling inwards and the gas pressure pushing outward.

This causes the Sun's core to contract, which causes the remaining particles to heat up, and in turn speed up nuclear reactions and makes the Sun brighter. As this happens, the gas around the outside of the Sun expands. Over the last 4 billion years, it has become around 20 per cent bigger, and it is still growing.

On shorter timescales, the power output of the Sun has been fluctuating too. Its atmosphere is stormy, and magnetic activity below the surface creates solar weather in the form of sunspots. They start out near the Sun's poles and move towards the equator, growing to planet-sized magnetic swirls. In the early 1800s, William Herschel noticed that when the number of sunspots dropped, the price of wheat rose. The weather on the surface of the Sun coincided with a period of drought on Earth; it seemed to affect the weather here. People started to track sunspots and noticed cyclical patterns: every 11

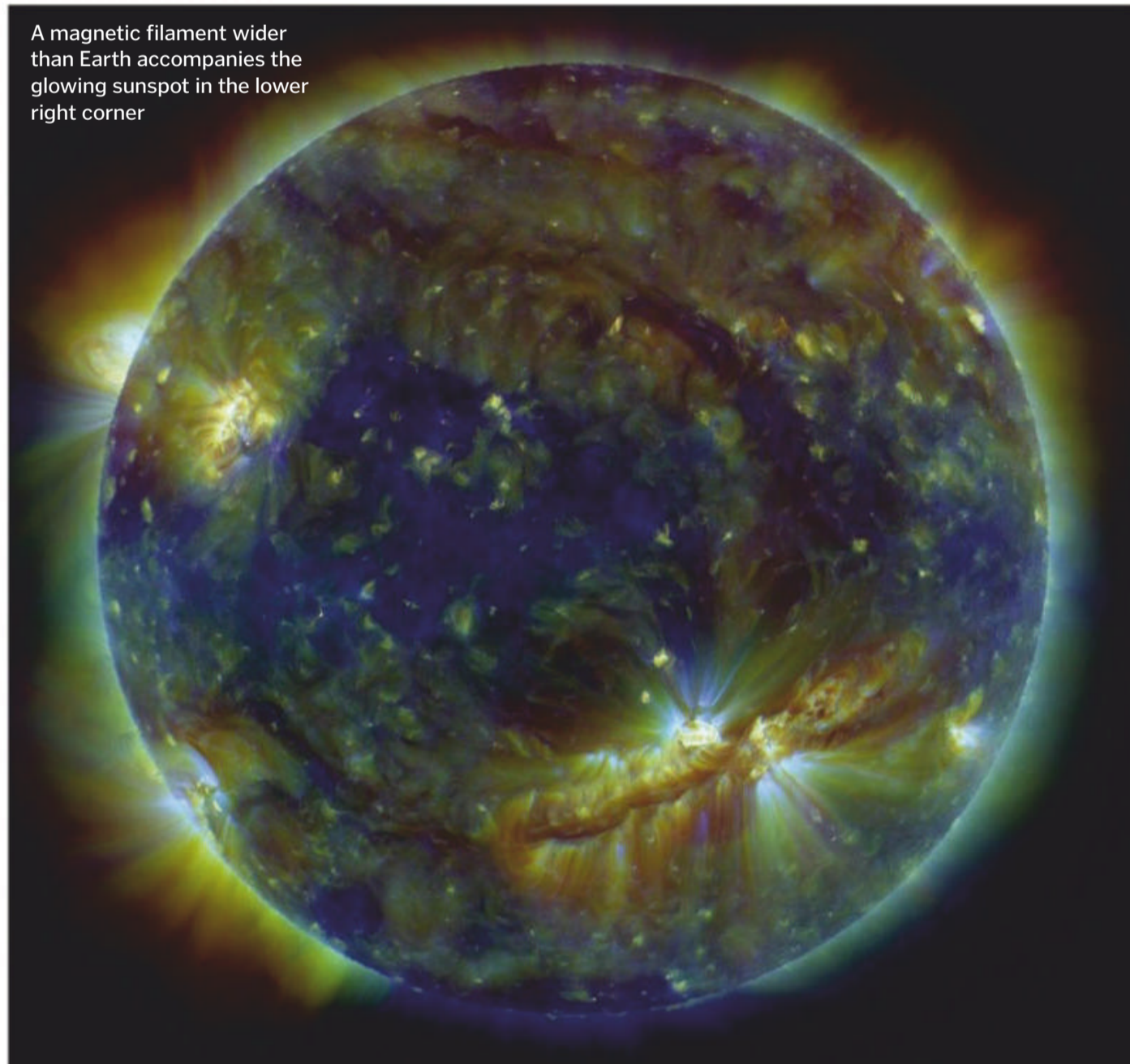

A magnetic filament wider than Earth accompanies the glowing sunspot in the lower right corner

Countdown to fusion power

Can TAE Technologies plug a fusion powerplant into the grid by 2023?

1998

Development and testing of the science begins, leading to more than 800 patents

2009

Construction of a full-scale machine is completed and equipment testing begins

2013

The system is upgraded with a powerful plasma injector, built by the Budker Institute of Nuclear Physics, Russia

2015

The temperature in the reactor reaches 10 million degrees Celsius – for full fusion, it needs to reach 3 billion degrees Celsius

2018

After 4,000 experiments, the system nearly reaches 20 million degrees Celsius

2023

The target temperature will be reached, the technology will be licensed and construction of fusion power plants will begin

“Photosynthesis provides the raw materials for almost every food web on the planet”

years, the number of sunspots rises and then falls again.

We still don't know why this solar cycle is 11 years long, but it could be to do with the dynamo effect inside the star. The Sun's convection zone contains a soup of charged particles called plasma. These particles are in constant motion, heated from below and swirled by the Sun's rotation. This creates powerful currents that set up toroidal (rings that follow the lines of latitude) and poloidal (rings that follow the poles) magnetic fields. At different points in the solar cycle the fields change in strength, which changes the way they interact, altering the sunspots on the surface. The variations in the Sun's output across the cycle are small, but sometimes they add up to big changes on Earth. In the 16th century through to the mid-19th century, as the number of sunspots dipped, the world plunged into the Little Ice Age.

Ice ages pale into insignificance when compared to what's to come. The Sun is about halfway through its life and, as it ages, its output is set to change dramatically. When it runs out of hydrogen in its core, it will start to use the hydrogen in the shell outside. Helium will continue to accumulate beneath, and as the core gets bigger the Sun will start to swell. It will grow brighter and hotter and the fusion reactions will proceed faster and faster, until it burns more than two times as fiercely as it does today. This

will scorch the surface of the Earth, raising the temperature to more than 300 degrees Celsius.

Eventually the hydrogen will run out. Then, the Sun will ignite in a helium flash and its core will start to fuse helium nuclei, transforming them into heavier elements like carbon and oxygen. In the process, the Sun's outer layers will swell, and it will become a red giant, 34 times brighter than it is now. The Sun will swallow Mercury and Venus, and Earth's surface will melt into pools of molten metal. By this time, the Sun will be hundreds of times brighter and hotter than it is today, and Earth's rocks will start to boil away.

When all the helium is gone, the Sun's fusion reactor will switch off. Its outer layers will cool and its atoms will blow away into space, forming a swirling planetary nebula and a white-hot core. This core, a white dwarf, will eventually cool until it is a dead, black cinder, and the light in our Solar System will go out forever.

Learn more

To discover more about the Sun, take a trip to the Science Museum to see and experience its special exhibition, *The Sun: Living with Our Star*. It's open until 6 May 2019, and kids aged 16 and under go free. Visit bit.ly/2GDEDS5 for more information about the exhibition.

"The Sun will swallow Mercury and Venus, and Earth's surface will melt into pools of molten metal"



Lichens form when algae and bacteria capture energy from the Sun and share it with fungi

LIFE IN THE SHADOWS

Where, in Earth's darkest places, do microbes make their energy independently of the Sun?



Hydrothermal vents

RIFTS IN THE OCEAN FLOOR

Some organisms have discovered a way to make energy from the hydrogen sulphide that leaks out from hot volcanic vents under the sea. Microbes combine hydrogen sulphide with water and carbon dioxide to make sulphur and glucose. Giant tube worms then store the microbes and use their waste to stay alive in the dark.



Methane seeps

CRACKS IN EARTH'S CRUST

Cold seeps can also sustain life without sunlight. These seafloor biomes leak bubbles of methane and hydrogen sulphide into the water, which can then feed colonies of bacteria. The bacteria form mats on the ocean floor, and they can provide enough energy to sustain beds of mussels and also groups of tube worms.

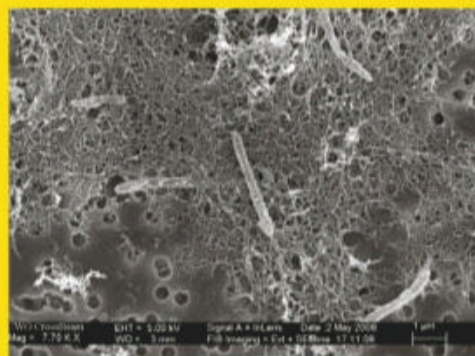

Volcanic rocks

THE CREVICES BETWEEN GOLD MINE ROCKS

The gold mine bacteria *Desulforudis audaxviator* lives in total darkness, nearly three kilometres below South Africa's surface. It survives at temperatures above 60°C with nothing but rocks to eat. It gets power from the radioactive decay of uranium and is able to extract carbon and nitrogen from the rocks.



Under Antarctic ice

BENEATH POLAR ICE SHEETS

Rock-eating microbes found 0.8 kilometres below the surface of an Antarctic ice sheet may also be able to survive without the Sun. Like their cousins in the hot hydrothermal vents, these microbes extract energy from compounds containing sulphur and also iron. But temperatures in this environment here are below freezing.

91% 

Proportion of atoms that are hydrogen

¹H
1.008

70.6%

Proportion of mass that is hydrogen

5,500
degrees Celsius

Temperature at the surface



3.8×10^{26}
Watts

Power output every second



LET THERE BE LIGHT

The Sun is the powerhouse of the Solar System. So let these impressive facts enlighten you

150 million kilometres

Distance between the Sun and Earth



2 million
degrees Celsius

Temperature of the Sun's atmosphere



600 million tons

Hydrogen used up every second



5 billion years

Until the helium-burning process begins

1,391,016 kilometres

Diameter at the equator

15 million degrees Celsius

Temperature at the core



SUBSCRIBE

to **How It Works** and get a
**FREE POCKET
MICROSCOPE***

There are worlds waiting to be discovered with the aid of a powerful lens. An in-built light reveals the tiniest details. It's an ongoing favourite with bright-eyed young scientists and parents alike



SPECIFICATION

Up to 40x magnification, perfect for curious young scientists

INCLUDED

Features two specimen slides, a lens-cleaning cloth and full instructions

BRAND

So popular that it is one of the Natural History Museum's all-time bestsellers

SIZE

A portable wonder. Small at 11.5 x 8 x 3cm but powerful



WHY SUBSCRIBE?

- Brilliant value – save money on the cover price
- You'll never miss an issue
- It's delivered direct to your door



Subscribe now
www.myfavouritemagazines.co.uk/hiw/123m
 or call 0344 848 2852 & quote HIW123M



PRINT

Six-month subscription to **How It Works** in print, plus a free Natural History Museum pocket microscope

£20.50



PRINT & DIGITAL

Six-month subscription to **How It Works** in print & digital, plus a free Natural History Museum pocket microscope

£23



*Terms and conditions: This offer entitles new UK Direct Debit subscribers to pay just £20.50 every 6 months plus receive a Pocket Microscope. Gift is only available for new UK subscribers. Gift is subject to availability. Please allow up to 60 days for the delivery of your gift. In the event of stocks being exhausted we reserve the right to replace with items of similar value. Prices and savings quoted are compared to buying full-priced print issues. You will receive 13 issues in a year. Your subscription is for the minimum term specified. You can write to us or call us to cancel your subscription within 14 days of purchase. Payment is non-refundable after the 14 day cancellation period unless exceptional circumstances apply. Your statutory rights are not affected. Prices correct at point of print and subject to change. UK calls will cost the same as other standard fixed line numbers (starting 01 or 02) or are included as part of any inclusive or free minutes allowances (if offered by your phone tariff). For full terms and conditions please visit: www.bit.ly/magterms. Offer ends 18th April 2019
 Direct Debit Originator's reference 768195



SOLAR SYSTEM SUPERSTORMS

What's the weather like on other planets? Expect methane rain, global haboobs and a 16,000-kilometre wide hurricane

Words by Jonathan O'Callaghan

Our Solar System is home to some weird and wonderful weather, with storms more terrifying in their scale than anything in Earth's recorded history. From centuries-old hurricanes on Jupiter to immense winds on Neptune, if you happen to leave Earth then you'll be shocked by what you find.

On Mars you will find immense dust storms that cover the entire planet, and Venus has an incredibly thick and fast-moving atmosphere that can form permanent vortices at its poles. On Jupiter and Saturn there are some huge storms – bigger

than the diameter of multiple Earths – that have raged for decades or even centuries. And on the ice giant Neptune, you'll find the fastest winds in the Solar System, and within Neptune and Uranus it may rain diamonds.

Thanks to recent missions, we have learned more about these fascinating weather systems than ever before. We're also performing long-term studies of weather systems, such as storms erupting from the Sun that can have direct effects on Earth. As we continue to reach into the unknown, who knows what else there is to discover in the Solar System?

Eyes on Jupiter

NASA's Juno spacecraft, which entered orbit around Jupiter in 2016, has been sending back incredible data about this gas giant. Jupiter is the largest planet in the Solar System, but it's also home to some amazing weather and features, and Juno has been using an array of instruments to study it. This includes a microwave radiometer to measure the deep atmosphere of Jupiter. Juno also has ultraviolet and infrared cameras to take images of the planet's atmosphere and its aurorae. The spacecraft's JunoCam has also been busy snapping visible light images, returning amazing views of features like the Great Red Spot.

Juno's mission over Jupiter is currently scheduled to continue until July 2021, although that could be extended. The mission is trying to tell us more about how the planet works and discover what's inside the planet, which might explain some of the amazing weather we see in its clouds.



Juno swoops just a few thousand kilometres above the clouds of Jupiter

Jupiter's Great Red Spot

This iconic storm has been raging on Jupiter for centuries, but it may not be around forever. This giant spinning storm is comparable to a hurricane on Earth, although it is considerably larger. It measures about 16,000 kilometres across, which is roughly 1.3 times the width of our planet. We think its roots go up to 100 times deeper into Jupiter than Earth's oceans. Recent evidence, however, suggests the storm may be shrinking and could have just decades left to exist.



At one point, Jupiter's Great Red Spot could fit three Earths inside it

Saturn's lightning

Amazingly we've not only seen lightning on Saturn, but we've also heard it. NASA's Cassini spacecraft, which orbited Saturn from 2004 to 2017, was able to spot lightning on the planet in the daytime, meaning it must have been incredibly intense – some bolts are thought to be 10,000 times more powerful than those on Earth. By observing radio emissions from the planet, Cassini was also able to 'hear' the storms discharging in the atmosphere.



A lightning flash seen on Saturn by the Cassini spacecraft

The Sun can unleash powerful storms that race towards our planet

Solar storms

The Sun can cause havoc to our planet. Its solar storms consist of bursts of radiation and charged particles, which can seriously damage satellites in orbit or even technology on Earth. We use a variety of spacecraft to keep a close eye on the Sun's activity and prepare for the worst, but occasionally, when a large storm heads our way, we need to switch satellites and power grids off so they can ride it out.

Various spacecraft have spotted dust devils on the surface of Mars

© NASA, JPL-Caltech, SwRI, MSSS, Gerald Eichstädt, Sean Doran; Space Science Institute, University of Iowa; NASA's Goddard Space Flight Center



Extreme space weather

Where else can we find amazing weather in the Solar System?

Eternal darkness

Some craters on the Moon, Mercury and elsewhere lie at such an angle that they never see sunlight. Temperatures there plummet to near absolute zero (-273.15°C).

Summer holiday

The temperature on Venus can reach 465°C, as its thick atmosphere traps heat, making it the hottest planet in the Solar System.

Jupiter's radiation

The intense radiation from Jupiter bathes some of its moons, like Io and Europa, in deadly radiation.

Dust devils

On Mars, miniature tornadoes called dust devils form and move across the surface.

Vortices

Jupiter's north and south poles have strange arrays of cyclones arranged in a circle.

These images were snapped by the European Space Agency's Venus Express spacecraft, which orbited Venus from 2006 to 2015

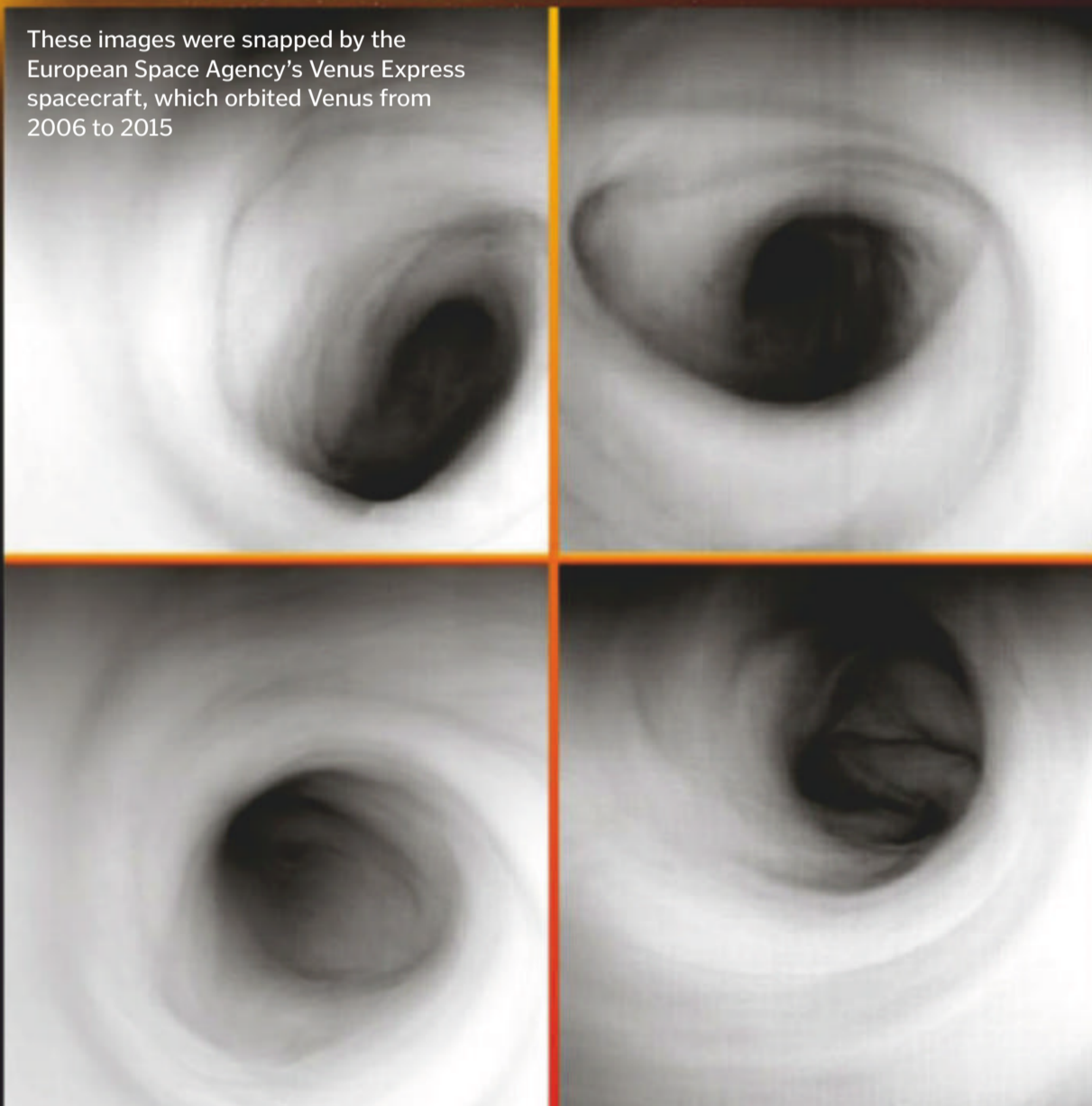

Venus' vortex

At the south pole of the Solar System's hottest planet, Venus, is a large vortex the size of Europe swirling in the atmosphere. This vortex appears to have been around for a long time and is a result of some strange properties on the planet. Venus' atmosphere actually moves faster than the planet, reaching speeds of up to 400 kilometres per hour – 60 times faster than the planet rotates.

Neptune's mega wind

Neptune, the farthest planet from the Sun, has the fastest winds in the Solar System. At the highest altitudes of the planet, where methane gives the planet its blue colour, winds can reach speeds of more than 2,000 kilometres per hour, or 1.6 times the speed of sound. These immense winds also give rise to some large storms, such as the famous 'Great Dark Spot' seen by the Voyager 2 probe in 1989.

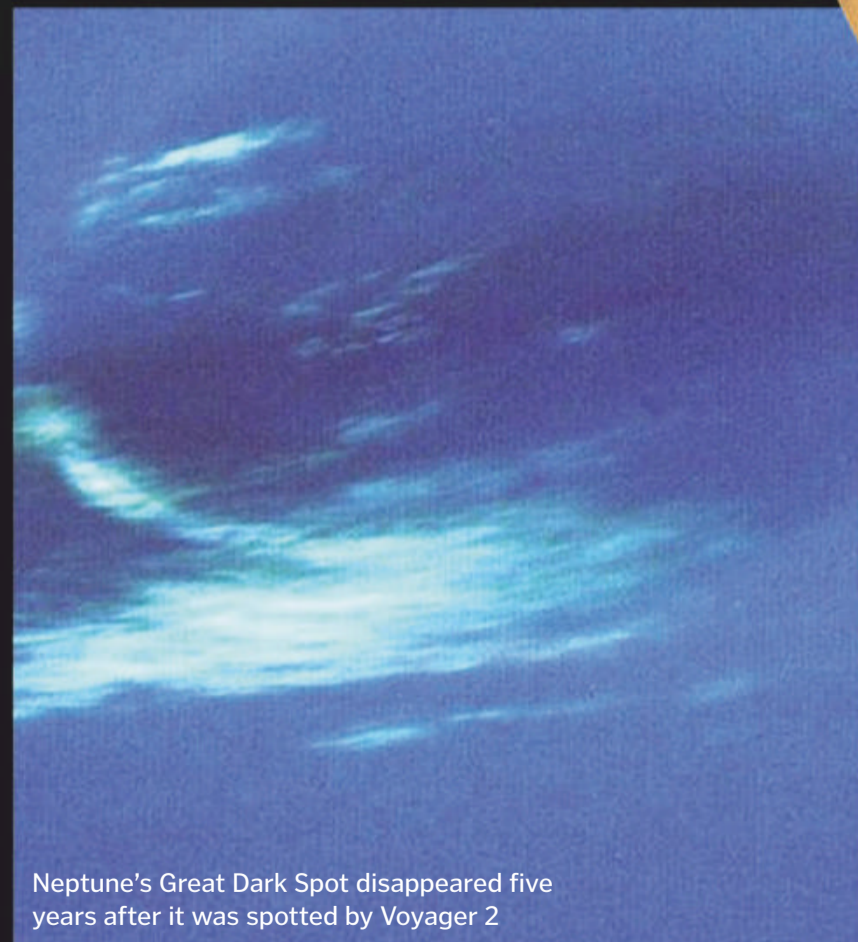

Neptune's Great Dark Spot disappeared five years after it was spotted by Voyager 2

What a hex

Saturn's north pole plays host to a weird, permanent hexagon of clouds that extends deep into the planet.

Monster storm

Saturn occasionally develops massive storms that extend more than 300,000 kilometres, encircling almost the entire planet.

Oddball Uranus

Despite rotating on its side, weather on Uranus mimics that found on the other giant planets.

Methane rain

On Saturn's moon Titan, methane occasionally falls as rain, after it evaporates from the surface and forms thick clouds.

This infrared image, taken by the Juno probe, shows the weird cyclones at Jupiter's north pole

Martian dust storms

In 2018 a huge dust storm engulfed the surface of Mars, obscuring its surface from our view. These storms, known as 'haboobs' when they occur on Earth, are fairly regular on Mars, occurring every few years, but this one was particularly large. They are caused by the Sun heating the atmosphere of the planet, lifting dust off the ground – although scientists aren't sure how they grow so big. They pose problems for solar-powered rovers on the surface, which rely on the Sun's light.

Dust storms can make it difficult to see the surface of Mars

Solar System stats storm

Our studies of the Solar System have revealed some incredible facts

100x Magnetic field of Earth compared to Mercury

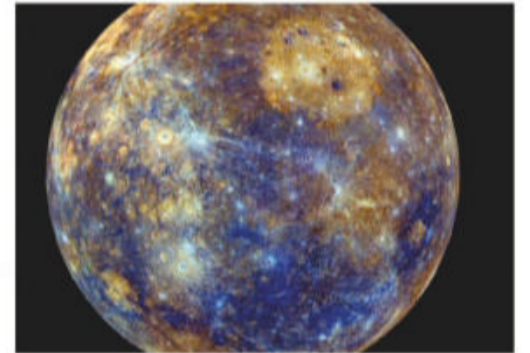

29 Number of Earth years between each methane rainstorm on Titan



94°C Difference between day and night temperature on Mars' surface in summer



11 Number of previously unknown moons orbiting Uranus, found by Voyager 2

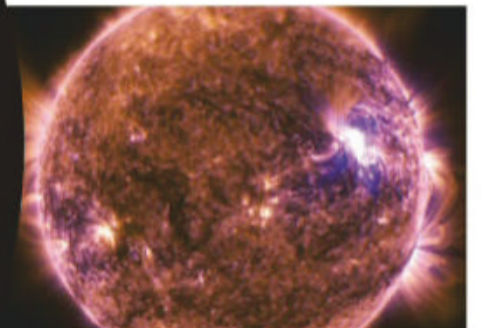

92x Atmospheric pressure on the surface of Venus compared to Earth

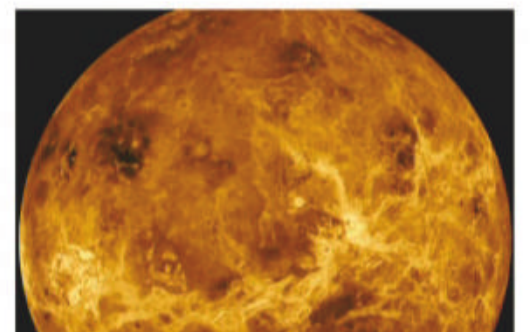

© Mary A. Dale-Bannister/Washington University in St. Louis/NASA/SDO/JPL-Caltech/Johns Hopkins APL/Steve Graben/Jenny Motar/MSSS/SWRI/ASI/INAF/JIRAM/ESA/Venus Express/VIRTIS/INAF/IASF/Obs. de Paris-LESIA



Determining the size of the universe

Measuring the enormity of space is a task best left to the professionals – and even they don't know!

The universe is a vast space that is simply incomprehensible to the human mind. The distance between London and New York is considered a large distance by many, but it pales in comparison when you think that it would take 2.5 million years to get to our closest galaxy while travelling at the speed of light.

Astronomers have spent decades trying to determine the size and age of the universe, and their closest estimate to the size of the observable universe is 46 billion light years across. This is just the area that astronomers can observe, and in fact they think it could even be double that size. The way they have managed to estimate such a number is through the use of astronomical distance

measuring beacons that are known as 'standard candles'.

The premise is simple. In the same way that you know what the brightness of a candle is while you hold it in front of you, it will gradually appear dimmer the farther it is from you. By measuring the difference in actual and perceived brightness, the distance between you and the candle can be determined. Astronomers use the same method on astronomical objects, and in the case of this research, a group of stars known as Cepheid variables are used. They have been studied for a long time using telescopes such as NASA and ESA's Hubble Space Telescope, and provided help in deducing this mind-boggling figure.



Standard candles are just one of the methods used in the Cosmic Distance Ladder

How brightness variability can measure distance

Cepheid variables are stars that are extremely useful when it comes to measuring cosmological distances. They are unlike the Sun in that they are usually between four and 20 times more massive than our own star and are much further along in their lifetime. At this later stage, they exhibit a brightness variation due to an inherent instability in the star that causes pulsations and this is used to calculate distances of a few tens of millions of light years.

Astronomers determine the rate of this pulsation, which is the period of variability, of the Cepheid, which has its brightness (or luminosity) inferred by the 'period-luminosity relationship'. The longer their variation the brighter the star is and vice versa. From this relationship, astronomers can use Cepheids as standard candles in their mission to measure the universe.

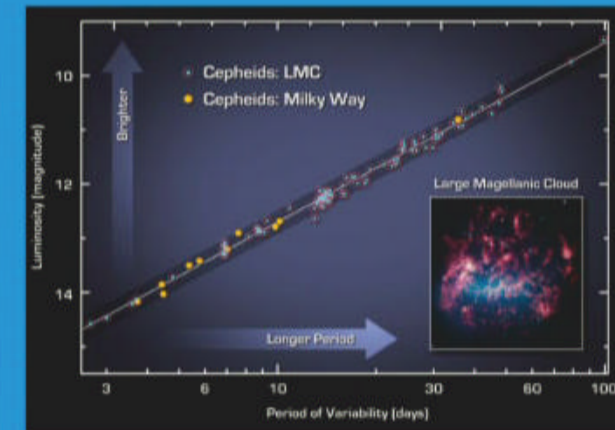

The timing of a Cepheid pulse is related to its luminosity allowing a distance to be calculated

Putting the universe into scale

From the Solar System to the Cosmic Microwave Background, the observable universe is filled with majesty

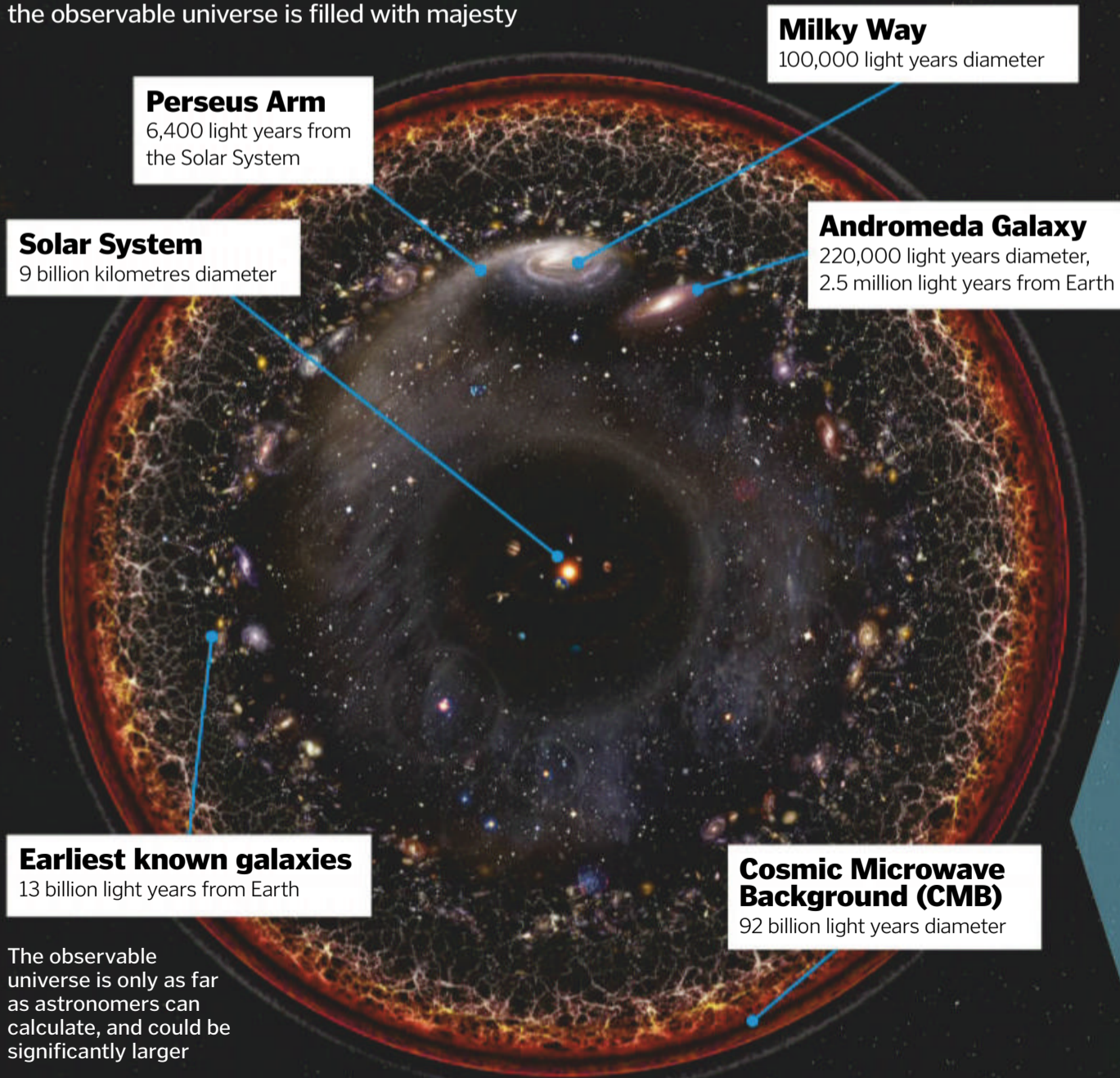

The observable universe is only as far as astronomers can calculate, and could be significantly larger

The universe beyond our Solar System

Nicolaus Copernicus may have something to say about this picture, but it's not saying the Solar System is at the centre of the universe. It's an illustrated logarithmic scale concept of the universe we can see. This piece was created by Pablo Carlos Budassi, a musician and artist, and inspired by logarithmic maps created by researchers at Princeton University, New Jersey, US. The picture was created to show how the universe changes logarithmically the further we peer beyond our Solar System, showing stars, galaxies and even the gas created after the Big Bang.

© NASA, NASA/JPL-Caltech/R. Hurt (IPAO); PABLO CARLOS BUDASSI



QUICK-BUILD



J6015
Blue Beetle

J6023
Yellow Beetle



4	4.07 m	1.5 m
1.54 m	725 kg	115 km/h
7.5 L/100km	23s 0-100km/h	40 kW



1.2L Flat 4

- Comes in two colours, J6015 Blue and J6023 Yellow
- Includes 36 plastic parts
- 18cm long when assembled
- Sticker sheet included for authentic decoration
- Has smooth lines just like the real thing
- Compatible with other plastic brick brands!



A Model for the People – VW's Most Iconic Car

The Volkswagen Beetle, or its official title the Volkswagen Type 1, was the first car to be produced by the company we all know today as Volkswagen. The Beetle has a very interesting history of how it came to be that you may not expect of this iconic car.

The idea was formulated by Nazi leader, Adolf Hitler, who wanted a simple, mass-produced, cheap car to be manufactured for his country's new road network. Chief engineer for the project, Ferdinand Porsche, finalised the design of the functional "People's Car" in 1938. The result was a rear-engined air-cooled saloon which was rugged, simple and reliable in any sort of extreme weather conditions.

The name has also stuck around ever since as "Volkswagen" literally translates from German as "people's car."

The Volkswagen Beetle entered the record books as the bestselling single-model car of all time on February 17th 1972 when production reached 15,007,034 units, beating the previous record of the Ford Model T. When production finally ceased on July 30th

2003, Volkswagen had produced a total 21,529,464 and it's unlikely this record will be broken again as cars now rarely remain in production longer than 10 years.

Although Volkswagen's legendary advertising campaign for the US market highlighted the fact that the Beetle did not change year-on-year, making it easier to source parts, it did develop over the years because of both market pressure and legislative changes. The first obvious visual change was in 1953 when the vision-limiting 'split' rear-window was replaced by a one-piece oval design, which lasted until August 1957 before being superseded by an even larger rear-window.

The VW Beetle has become a true icon on roads all over the world! You can create your very own at home with an Airfix QuickBuild kit. QuickBuild kits give you the ability to recreate a wide variety of iconic aircraft, tanks and cars into brilliant scale models. No paint or glue is required, the push together brick system results in a realistic, scale model that is compatible with other plastic brick brands.

Collect them all! Check out the rest of the range online.



J6019 Lamborghini Aventador



J6022 Challenger tank



J6020 Bugatti Veyron



INSIDE A ROBOT WAREHOUSE

ONLINE RETAILERS LIKE OCADO ARE REVOLUTIONISING SHOPPING THANKS TO THE HIVE OF ROBOTS HANDLING THE ORDERS

Words by Lee Cavendish



Gone are the days of human inefficiency, as Ocado – one of the UK's leading online supermarkets – delves into futuristic capabilities by embracing robotics. This supermarket has a dream like no other: to make online shopping as efficient as possible by minimising the need for human interference. From the point at which you click the 'Place Order' button to the moment it arrives at your door, the process will be completed by robots. The emergence of the innovative Ocado Smart Platform (OSP), developed by Ocado Technology and Cambridge Consultants, has been a huge step into the future.

There are two warehouses – also called Customer Fulfilment Centres (CFCs) – in the UK that utilise these latest technological feats. These warehouses look like a huge mechanical chess board, with a fleet of robots making their own moves around a grid the size of three football pitches. In each segment of the grid are the products that Ocado offer, offloaded by warehouse staff and placed into the grid. Sitting above them are the robots working together via a localised 4G network. This network allows the robots to communicate

with the base station, understand which items they need to collect and which order to do it in using its algorithms. Like an air traffic control system, this process is performed with optimum efficiency, ensuring no crashes occur. With over a thousand robots operating at once, it operates at a level that is unattainable by humans and capable of completing a 50-item order in just five minutes.

The technological advancements Ocado have made in the industry is a trend for the company: almost two decades ago the firm introduced automated trolleys that moved along the shelves, and then a few years ago it introduced a conveyor-based system. Combined with the OSP, these two warehouses will revolutionise online shopping, and the technology they've developed could even be sold to other companies.

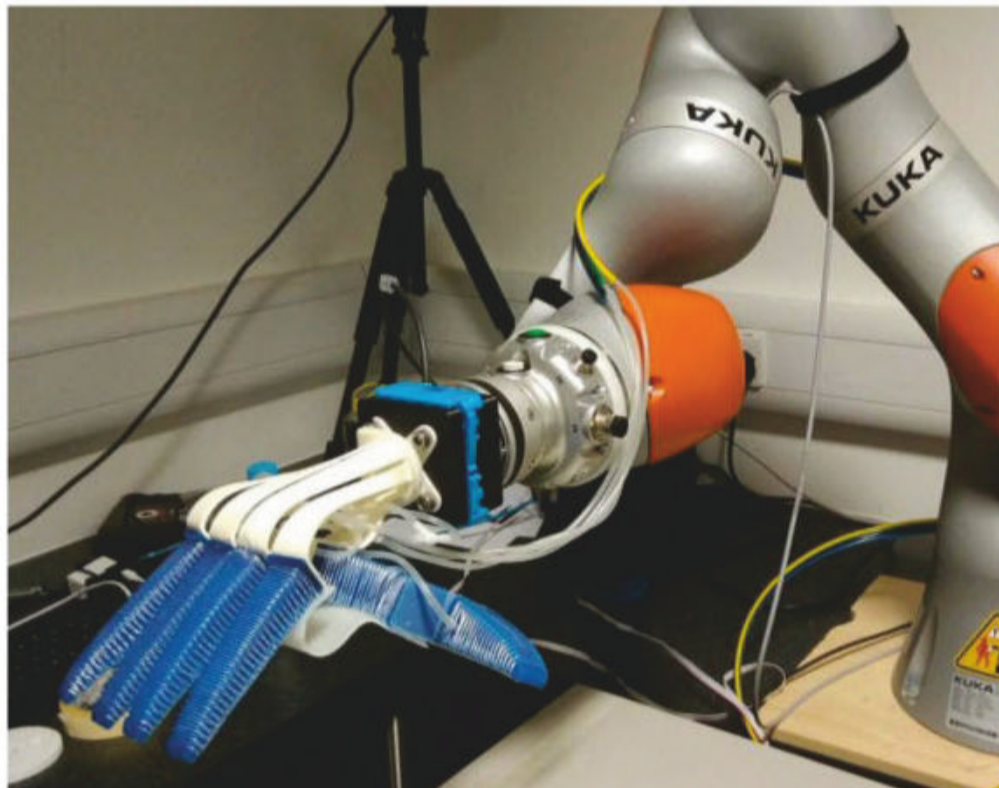

Ocado looks to roll this technology out in more warehouses across England

How do the robots communicate?

Saying that the robots communicate via a 4G network is a simplified way of putting it. The development team deduced that the wireless communication between robots had to either have a capacity large enough to satisfy the high-speed demands of over a thousand robots, or they would have to break up the communication into smaller sections. The engineers opted to use something called Orthogonal Frequency-Division Multiple Access (OFDMA), which basically splits up the data into different subsections.

The fact that the warehouse is isolated from the outside world means that communication benefits from the reduced signal noise from external sources. However, there is constant radio frequency interference from the metalwork within the warehouse. This could cause a delay in communications or the robots to miss a piece of vital data, which could lead to a serious problem within this highly efficient environment. To overcome this problem, the system uses sophisticated equaliser and error-correction software.



Delivering food to the door is the final step of an efficient process utilising sophisticated systems

OLD VS NEW

When compared, the new online-only way is simpler and saves time

1 Warehouse preparation of the past

The conventional way dictates that the products must be transported to a warehouse before it can be distributed to its store nationwide.

2 Delivered to the stores

Items are collected either by customer or delivery driver, before being brought home.

3 A longer wait

The time and effort involved can sometimes translate into a poorer experience for the customer.

4 The Ocado way

The Ocado way means that goods can be organised in one warehouse, without the need of a store.

5 Speedy delivery

The robot hive's swift and efficient picking should ensure you get your purchase on time, every time.

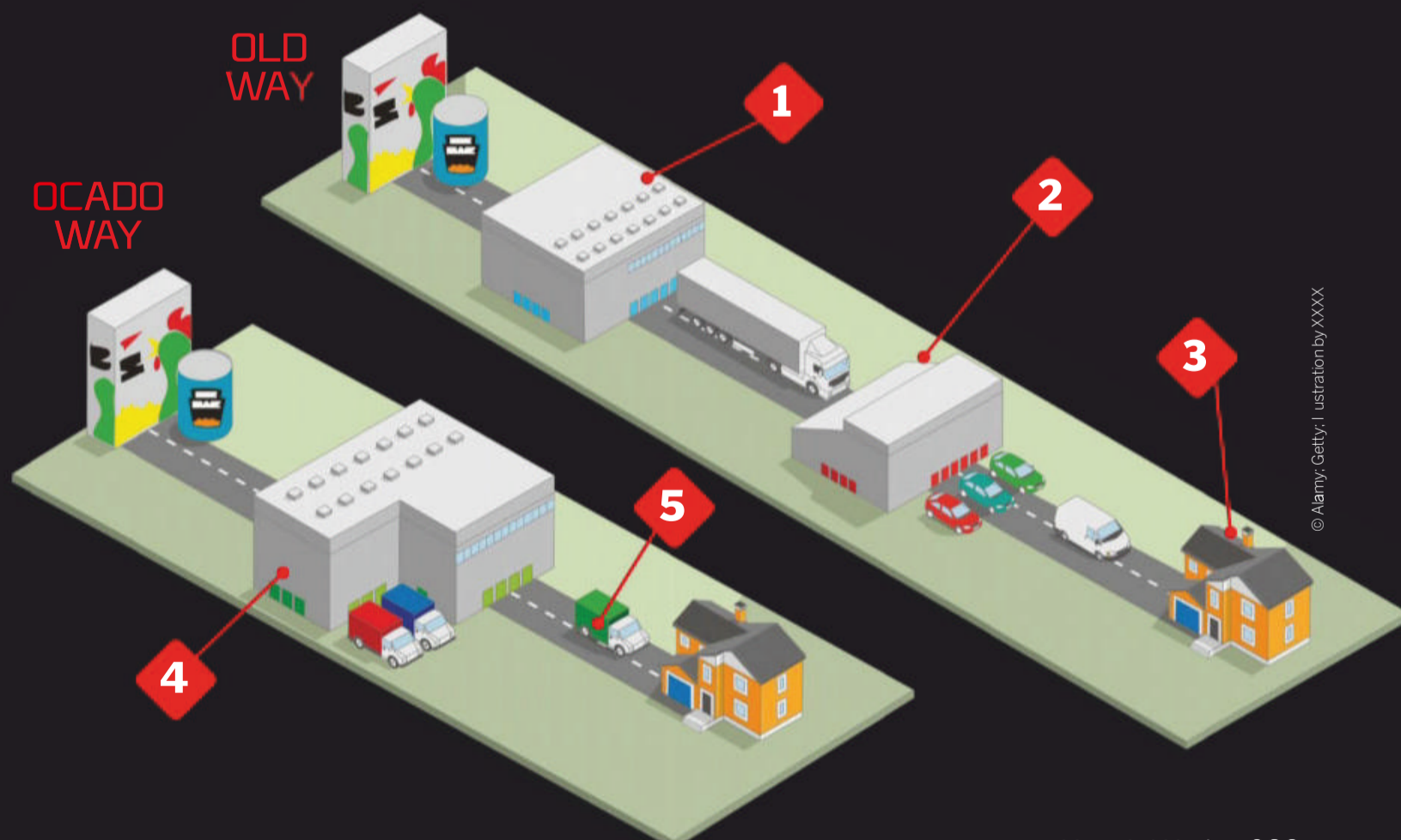

© Alamy; Getty; Illustration by XXXX



THE INNER WORKINGS OF THE WAREHOUSE

Both humans and the robotics must work together to ensure a fruitful delivery system

Working together to collect the order

Based on algorithms and control mechanisms, the grid is effectively controlled as an air traffic control system to collect the orders.

Set up in the grid

Once set up, the robots will zip around above the stacks collecting orders in just a matter of minutes.

Plenty of room

The overall grid is the size of three football pitches, and in each section the items have been placed there by the use of artificial intelligence.

Delivery time

The collected orders then get sent to a different station where humans will pack all the items correctly, ready for delivery.

The wireless control system guarantees a great connection for robots in a 50-metre radius

It would take five minutes to pick and pack a 50-item order

Warehouse staff place the items into bags then vans once the robots have collected them

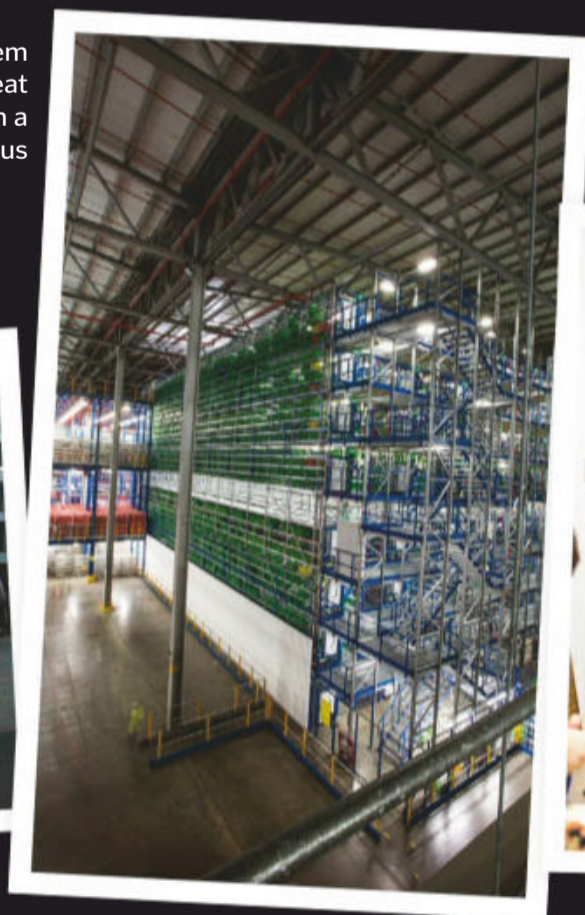

DID YOU KNOW? Each of the robots travels between 50 and 60 kilometres every single day!

OPERATING A SMART PICKING PLATFORM

The latest in warehouse logistics has led to this efficient, innovative and wireless game-changer

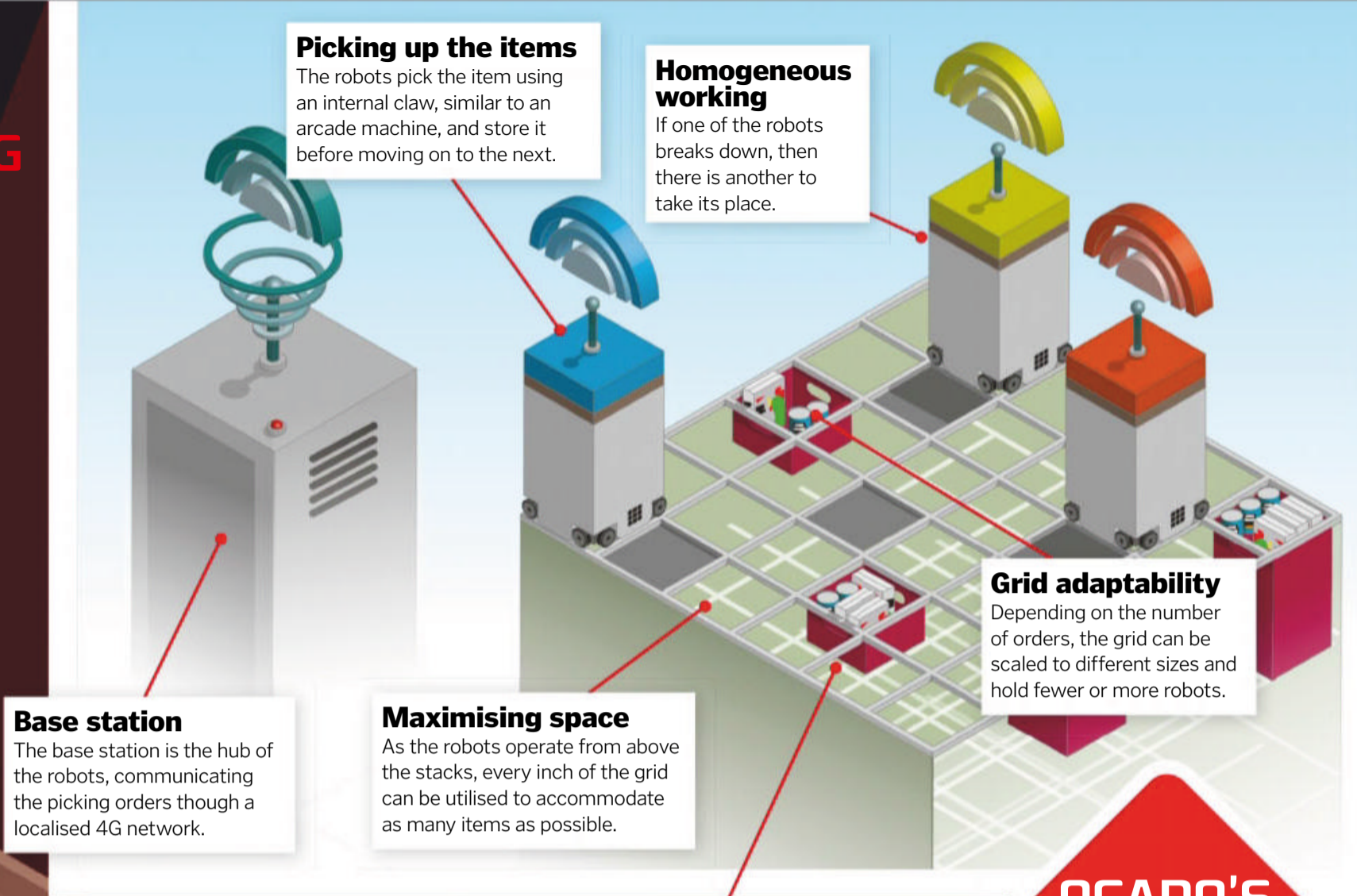

Stacking items
After the delivery has arrived, workers put them into stacks under the robots with their position determined by an algorithm for efficiency.

Unloaded from the truck
The items arrive in crates, which are then unpacked and loaded into stacks as high as 17.

OCADO'S WAREHOUSE NUMBERS

1,100

The number of robots operating at the warehouse

4G

A 4G wireless network is used for communication

112km

The length of the track the robots travel on if they were laid in a straight line

250,000

storage locations can be accommodated by the grid

3 million

routing calculations are performed by the system per second

65,000

orders are processed a week

"THE NETWORK ALLOWS THE ROBOTS TO COMMUNICATE"



REWINDING TIME

Discover how modern digital technology is helping us to restore and explore ruins of human history

Words by **James Horton**

The temples of Bagan are one of many integral sites documented by CyArk

Our world is steeped in history. In nearly every city on every continent, there are sights to be seen that remind us that our generation was not the first. They show us that those who came before had rich cultures and showed incredible ingenuity, and they inspire us to engage in their stories. Nothing is more immersive than physically observing an ancient ruin, a structure that has endured for centuries and stands as a testament to the society that constructed it. But these incredibly important sites that span the globe, these essential markers of civilisation, are under threat.

These threats have already claimed many wonderful relics. An erupting volcano may have preserved the impressions of ancient Roman life in the city of Pompeii and the neighbouring town of Herculaneum, but this is the exception rather than the norm. Destructive natural disasters, such as volcanic eruptions, earthquakes and tsunamis, have lain waste to entire ancient cities – with the storied Egyptian city of Alexandria being chief among them – and remain a potentially devastating danger today.

But nature is not alone in posing a risk to our ancient monuments. Warring peoples in the Middle East have deliberately torn down Buddhist statues in Afghanistan and ancient buildings in Palmyra in Syria. And tourists, who swarm to famous sites with the noblest of intentions, have irreversibly damaged structures like the Pyramids of Giza through improper care during their explorations.

Fortunately, concerned citizens are not alone in their motivations to preserve and protect ancient sites. Respected organisations like UNESCO are stepping in to guard world heritage locations, and a swathe of charities have sprung into life to reinvigorate or even resurrect damaged or destroyed structures. But with modern technology comes the opportunity to go one step further: to capture sites digitally. This is the mission of the US-based company CyArk,



LiDAR technology is also used in many self-driving car systems

whose founders were moved to act after hearing of the senseless destruction of ancient ruins by militant groups.

Using a combination of Light Detection and Ranging (LiDAR) technology and photogrammetry, CyArk not only documents details of ancient sites but captures them in their

“CyArk not only documents details of ancient sites but captures them in their entirety”

Preserving ruins in 3D

Scott Lee, director of production at CyArk



Can you tell us a little about your role as director of production?

Technically my job is to take whatever data is collected in the field and make sure it's turned into something that's

tangible or usable. This includes taking data for traditional architectural drawings or creating a VR (virtual reality) experience. I manage the system that makes sure everything gets to where it needs to be. We've done projects in Syria as part of Project Anqa where we educated Syrians on documentation and how to use the equipment.

Do you believe that VR will be the main way people enjoy ancient sites?

I think it'll always remain somewhat an accessory, as you can't replace a sense of 'place' and there are so many intangibles that you can't capture with VR. Aesthetically though, the virtual environments that we create are often better than reality. When we were documenting monasteries in Armenia we noticed that they were very dark inside, and you couldn't see all of the details. But a 100-megapixel camera with a three-second exposure offers a very different scenario, as you can see details that you previously couldn't see.

I also see VR helping the heritage field in creating accessibility at sites where you can't go because you may damage it. For example, ancient Corinth in Greece holds the Peirene Fountain, but the public's not allowed to go into that area and explore it because it's so fragile. So just being able to augment where people can go, even onsite, is a powerful use of VR, and I think that is where we are going to see it used in the future.



LiDAR systems and digital cameras are attached to drones to document inaccessible sites

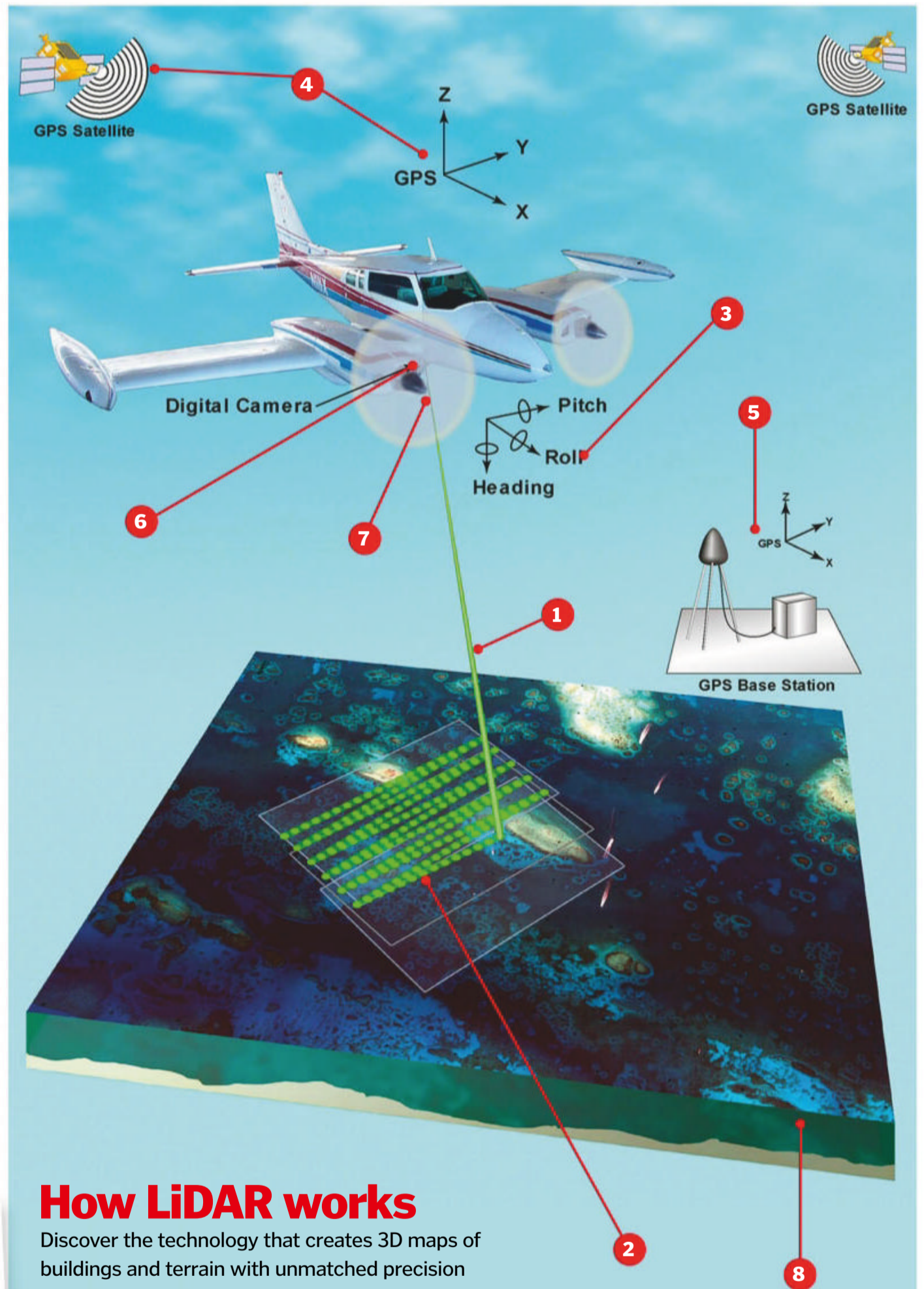

How LiDAR works

Discover the technology that creates 3D maps of buildings and terrain with unmatched precision

1 The laser beam

Up to 150,000 laser light pulses are fired at a surface every second. Micropulse systems are low power and need few safety precautions.

2 Mapping

Each millimetre of the target is struck by a pulse of light. These bounce off the ground and strike a photodetector that is mounted on the aircraft.

3 Coordination

An Inertial Measurement Unit (IMU) tracks the orientation of the sensor so that mapping isn't hindered by the aircraft turning.

4 Eye on the sky

Global Positioning System (GPS) satellites precisely monitor the location of the photodetector and IMU as the aircraft flies.

5 Keeping track

Accuracy is of paramount importance when using LiDAR for mapping. GPS base stations work with satellites to pinpoint the position of the aircraft.

6 Digital camera

Colours and texture are added to the 3D model by merging the data with digital imagery that's captured via a digital camera.

7 Photodetector

The time taken for the pulse of light to return to the aircraft determines how far away the struck point was.

8 Bringing it together

By knowing the precise location hit by every pulse and their distance from the aircraft, we can build a highly accurate 3D model of the surface.

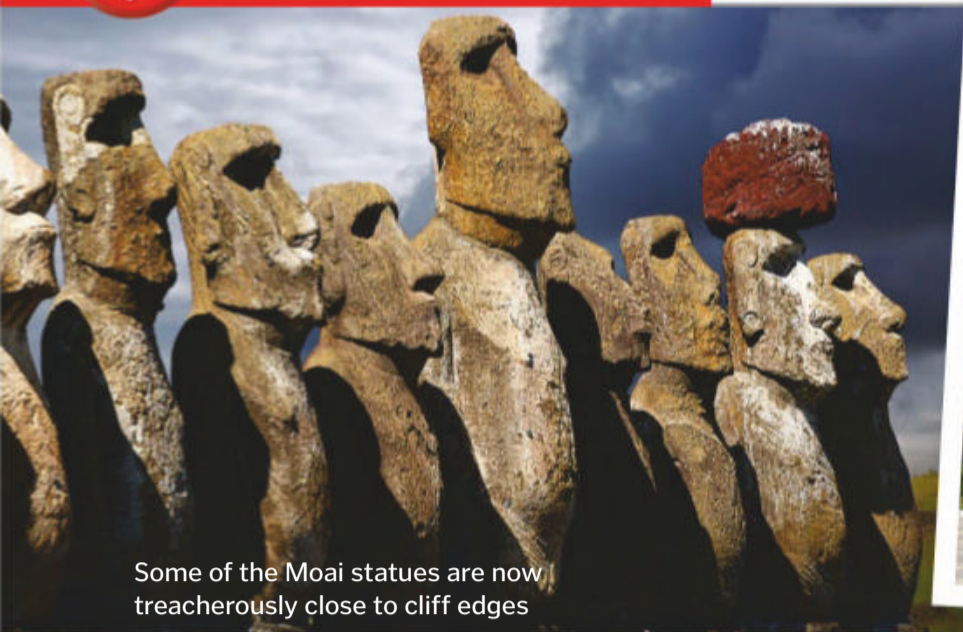

Some of the Moai statues are now treacherously close to cliff edges



The 18th-century Al Azem Palace was digitally captured to preserve it in case of destruction by people

entirety, creating a photorealistic 3D model. LiDAR is the core technique used for capturing the 3D blueprint of the structure. It relies on pulses of light being shot at and bounced back from the structure's surface to capture both depth and detail. LiDAR units can be handheld, or mounted on a drone or aircraft to document inaccessible and large spaces with immense precision. Photogrammetry is a complimentary technique that involves the use of digital imagery to gain measurement information and texture details. These are later blended with the LiDAR data to create a faithful, digital reconstruction of an ancient site.

Not only does this technology enable us to store a digital record of an ancient site and protect it from nature and humans, it also aids us in ensuring its future. In 2016 an earthquake struck the country of Myanmar and damaged hundreds of ancient temples in Bagan. Delicate

murals and temple spires crumbled and collapsed, but with the aid of CyArk's detailed models, restorers had the template they needed to return them to their original state.

As well as bringing the digital rendition back into reality, CyArk has strived to engage people directly with the virtual space. The accessibility of VR devices, and with digital reconstructions reaching true fidelity, we can now experience ancient wonders anywhere. Thanks to the models, we can explore an ancient structure and take in the sights in 3D. So not only are we now going further to protect the past, we're engaging more people with it than ever before.

Learn more

To learn more on the digital conservation and reconstruction of ancient sites, and how you can visit these amazing locations with the help of virtual reality, visit: www.cyark.org.

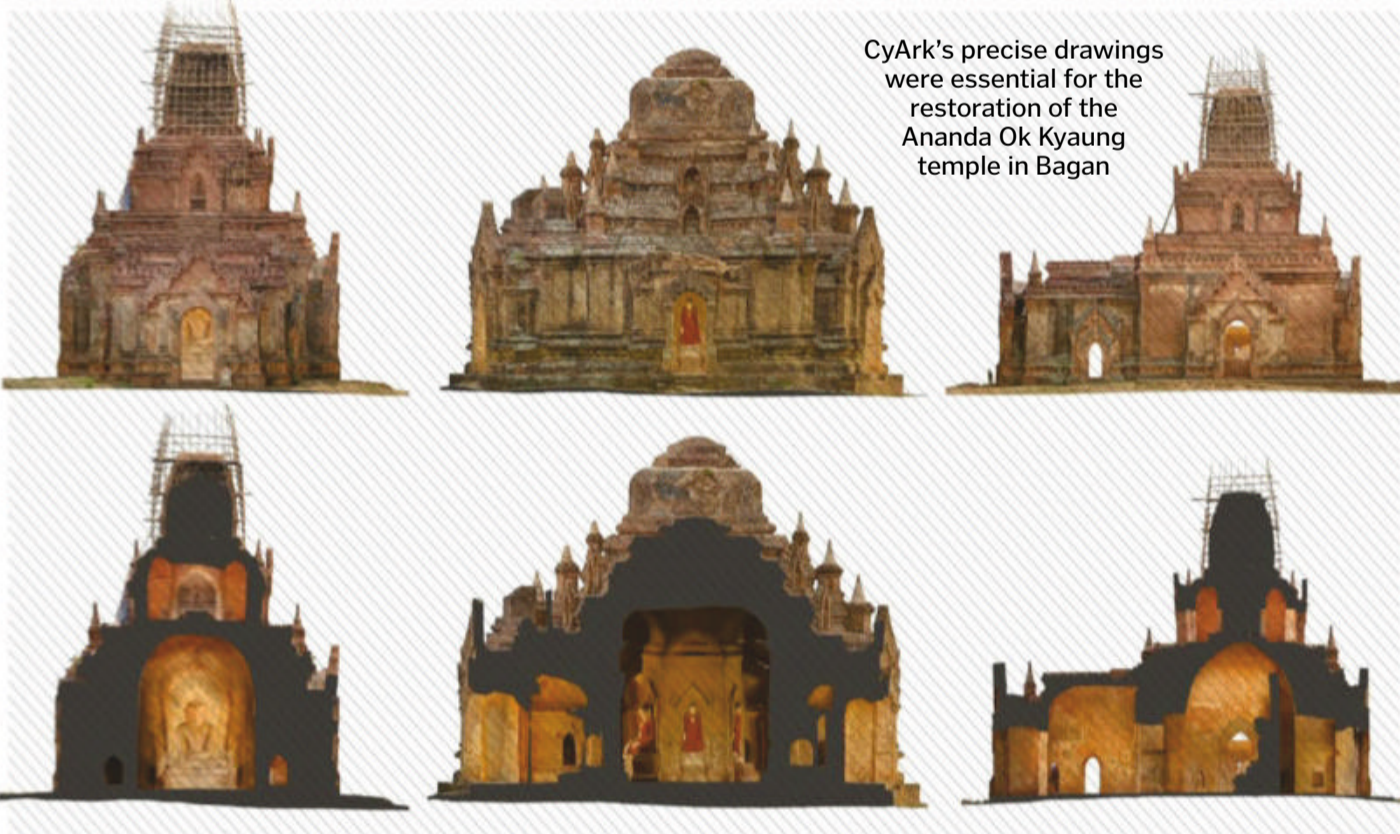

CyArk's precise drawings were essential for the restoration of the Ananda Ok Kyaung temple in Bagan

Rebuilding Bagan

After a 6.8-magnitude earthquake damaged hundreds of structures in Bagan in 2016, CyArk was key in providing detailed drawings for architects in their restoration efforts. Using 3D modelling data, the team provided accurate 2D slices of the structures that granted detailed information on the original internal and

external dimensions. These were used as an underlay to assess the site. The team returned to Bagan to image the structures again, this time contrasting the temples prior to and after the earthquake. With this information, the restoration of the Ananda Ok Kyaung temple was approved. Its rejuvenation is underway.

CyArk's completed conservation projects



1 The Peirene Fountain

Ancient Corinth, Greece

At the epicentre of ancient Hellenic culture, this important structure has now been closed to the public due to concerns about its preservation.

2 Bagan

Myanmar

Hundreds of temples have been damaged by a recent, regional earthquake, while the remainder of the 3,000 ancient sites remain at risk.

3 The Moai

Rapa Nui, Chile

The famous Polynesian statues enjoyed relative isolation for centuries, but with the arrival of Western explorers came tourism and increased risk to the monuments.

4 Rosslyn Chapel

Scotland

This 15th-century Gothic church bears unique and detailed carvings and stonework imbued with intriguing Christian symbolism. CyArk's conservation efforts have ensured that scholars will not lose this valuable resource.

5 Al Azem Palace

Syria

Built in 1750, the sprawling palace has two main wings, baths and a courtyard. It was digitally conserved in response to the deliberate destruction of historical sites in the region.

6 Tudor Place

USA

This Neoclassical building was home to six generations of US President George Washington's family. CyArk documented the building both prior to and after it was reconstructed in order to combat moisture infiltration.

THE PATH OF DIGITAL CONSERVATION

Walk the road CyArk travels, from data capture all the way to storage in the virtual vault

Data capture
LiDAR technology, either static or mounted on an aircraft, maps the structure in 3D.



Field processing
Approximately 500 gigabytes of raw data (enough to fill up a standard PC hard drive) is first processed onsite to ensure that everything has been captured.



Hand-delivered
A physical external hard drive holding the data is transported to CyArk's headquarters in Oakland, California.



Creating the model
The raw data, which is composed of millions of individual data points in geographical space, is transformed into a photoreal 3D model.



Reconstruction and immersion
The 3D model can be used to build an accurate virtual reality space, or to enable 3D printers to create scale-perfect recreations.

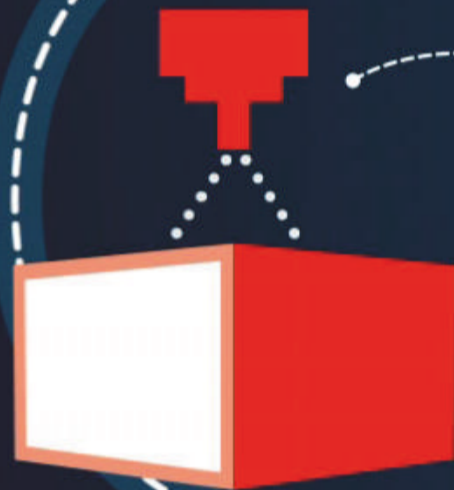

Big data
The completed site data reaches three terabytes (six times larger than the raw data).



Iron Mountain
A 'gold copy' of the site data is finally stored in a secure data storage facility known as 'Iron Mountain'.

Backup plan
The site data is backed up onto CyArk's in-office system, while a hard copy leaves for secure storage.

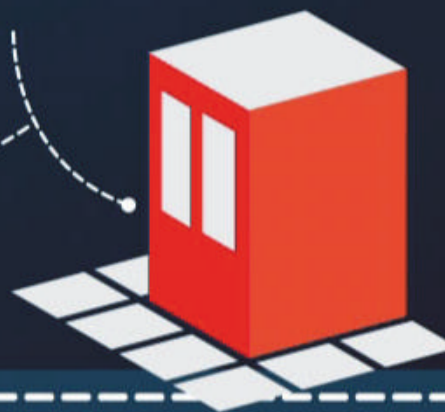

"With the aid of CyArk's detailed models, restorers had the template they needed to return buildings to their original state"





How to read braille

What is it about these tiny dots that lets them communicate the world's languages?

Braille, the tactile reading system blind people can use to read text, is in more places than you may first realise, from cashpoint keypads to restaurant menus and even on some supermarket products. It works by using six tactile dots orientated in two columns and three rows, known as cells. Each raised dot relates to a letter, a number or a punctuation mark. For example, the letter "a" is expressed as a single dot to the top left of the cell. Each letter has its own configuration of dots, spelling out words and sentences. There are two ways in which braille can be read, either as individual

letters of the alphabet or predetermined phrases or grouped letters, such as 'him or 'like'. Braille texts are created by a pointed stylus indenting a sheet of thick paper against a slate to create each tactile dot on the reverse. This is done through rolling machinery for publication printing or on braillewriter, which works in the same way as a traditional typewriter but with only six keys to create each dot in the cell.

According to the World Health Organization (WHO) 36 million people globally are blind, however, fewer and fewer people are using braille to read, due to audio alternatives.

Letters of the alphabet are allocated a Braille dot orientation, along with numbers and punctuation

ENGLISH BRAILLE ALPHABET

A	B	C	D	E	F	G	H	I	J	K	L	M
N	O	P	Q	R	S	T	U	V	W	X	Y	Z
1	2	3	4	5	6	7	8	9	0			

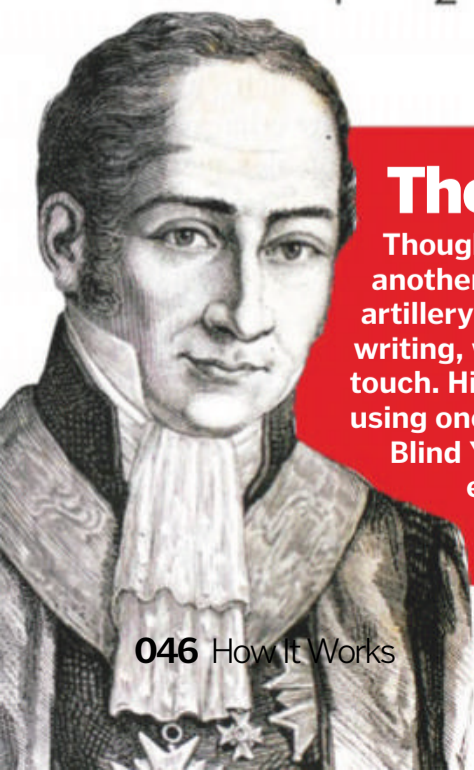

The night writer

Though braille bears the name of a man remembered for its creation, it was another who first used raised dots for writing. Back in the early 1800s, French artillery officer Charles Barbier de La Serre invented the technique night writing, whereby soldiers could communicate at night using messages read by touch. His system used a 12-dot cell, but it wasn't possible to feel all the dots using one touch. Barbier later lectured on his system at the Royal Institute for Blind Youths in Paris, which a 12-year-old student by the name of Louis Braille eventually improved upon, creating the modern six-dot cell version.

Artillery officer Charles Barbier was the first to create messages read by touch

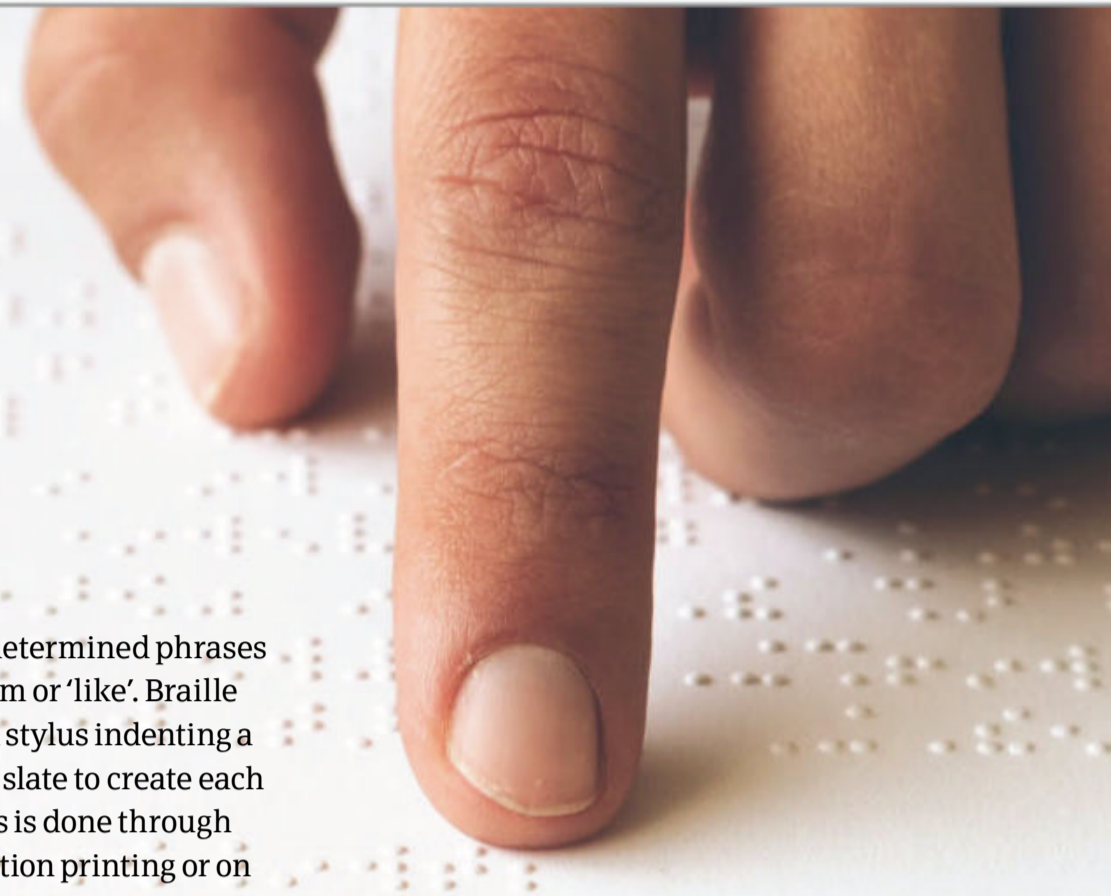

Braille is a method used by the visually impaired to read and write

How blind people read digital text

Though traditional braille is still used by many in the visually impaired community, the digital revolution has taken it from paper to plastic. Known as refreshable braille, several companies have created electronic braille readers to convert digital information into braille. These devices translate digital text and present it as braille through a series of cells comprised of changing plastic pins to replicate tactile dots. As the reader moves to the end of the line, the pins change to reveal the next line, and so on. Though refreshable braille devices offer a solution to reading digital text, it's not without its limitations. Typically devices are highly priced and offer only a single line of text at a time. Therefore, researchers at the University of Michigan are working to produce a tactile tablet, using air to create each tactile cell on a changing interface. It's a project they've aptly named the 'Holy Braille'.



The Royal National Institute of Blind People recently released their low-cost Orbit Reader 20

ADVERTISE
HERE TODAY

techcamp
.org.uk

Inspiring Tomorrow's Inventors



Easter Camp
Bookings Open!

EXCLUSIVE NEW COURSES ...



Build your own 3D printer to take home and learn 3D design in
3D Printing



Build & programme advanced robots with flippers & optical cannons in
Robowars



Build & race FPV drones & build a programmable LED race hoop in
Drone Racing



Create a sophisticated 3D game with the 'Unity' Game Engine in
3D Game Design

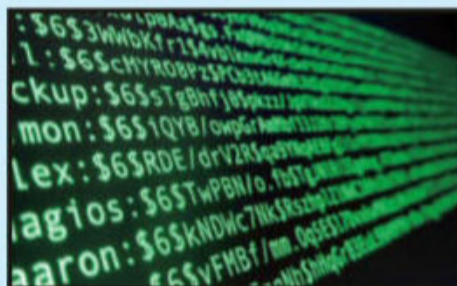

Learn about codes, build spy gadgets and explore cybersecurity in
Cyberspy Academy



Build a number of 2D games, and learn graphic and sound design in
2D Game Design

Come as a day camper at one of our three venues in the South of England, or join hundreds of other young people from around the UK and overseas at our flagship residential camps where you also spend evenings playing laser tag, learning extreme soldering and disassembling electronics.

Want to Know More?

Tech Camp is the UK's original camp of its kind and remains the only one specialising in teaching coding through advanced take-home projects. It's perfect for creative youngsters who like making things (or taking them apart!) or show those who are forever playing games how to start designing their own.

We have tutors from institutions like Cambridge & Imperial, maximum groups of eight, and exclusive courses not available anywhere else.

www.techcamp.org.uk info@techcamp.org.uk 0118 380 5678

HOW IT
WORKS

Want to advertise in our fact-packed science and technology magazine?

Call now on
01225 687368
or **01225 687374**.

Find out more about advertising with Future on www.futureplc.com.



ANIMAL ANTIDOTES

How do some creatures survive being bitten and stung by the most venomous nasties on Earth?

Words by **Scott Dutfield**

Whether it's the bite from a viper, a sting from a scorpion or the subtle swipe of a jellyfish, the world's venomous species have evolved the ability to deliver a killer cocktail of chemicals. However, there are those that have also evolved immunity to their fatal effects. There are roughly three types of venom among the more notorious of the 600 venomous species of snake. Neurotoxins affect the body's

nervous system, blocking communications between nerves and ultimately shutting it down altogether, resulting in paralysis. The second, hemotoxins, bring about a particularly gruesome demise. These toxins attack the body's red blood cells, making them coagulate to form gelatinous blood clots. Finally, cytotoxins are those that begin to digest the body's cells before the snake has even swallowed its prey.

As predators and as prey, venomous snakes are formidable opponents, but certain species are able to tackle them head-on without fear. The mongoose is the deadly cobra's worst nightmare. In order for this snake's neurotoxic venom to work the toxin must be able to bind with receptors on nerve cells. However, the mongoose's nerve receptors have mutated in a way that prevents this kind of bind, thus

Mongoose have evolved to resist the deadly venom of the cobra



Secretary birds use a force equivalent to five times their own body weight to strike their prey



Kung-fu birds

Snakes not only have to fear the threat of attack from land, but also the skies. Winged kung-fu killers, secretary birds have developed a martial arts method to feast on snake flesh. While not strictly anti-venom – they do not possess an internal immunity to tackle snake venom – these birds avoid bites by delivering several rapid-fire blows to a snake’s skull. One study found that on average it took just 15 milliseconds for the bird to strike the snake’s head. Delivering a 20-kilogram-force blow to the head, secretary birds are able to disarm a venomous snake without feeling the force of their bite.

Mongoose typically eat small animals such as snakes, birds and fish



Grasshopper mice have evolved the ability to simply brush off the sting of a scorpion



DEFENCE AGAINST VENOM

How have the honey badger's nerves adapted to resist neurotoxic venom?

Rodent resistance

The sting of a scorpion can be fatal to many rodents who come in close contact with them. There is one, however, that has baffled researchers for not only its ability to prey on these sting-equipped insects, but to do so unscathed. Native to the southwestern United States the grasshopper mouse has taken a liking to the taste of bark scorpion. Deadly to other animals, when stung the desert-dwelling grasshopper mouse simply licks its paws and finishes its meal. It's still unclear exactly how the mouse is immune to the scorpion's sting, though it is thought to be related to a protein released at ion channels on the rodents' nerve cells. By binding with the injected toxin, these proteins are thought to actually create a numbing effect, reducing any pain felt by the mouse.

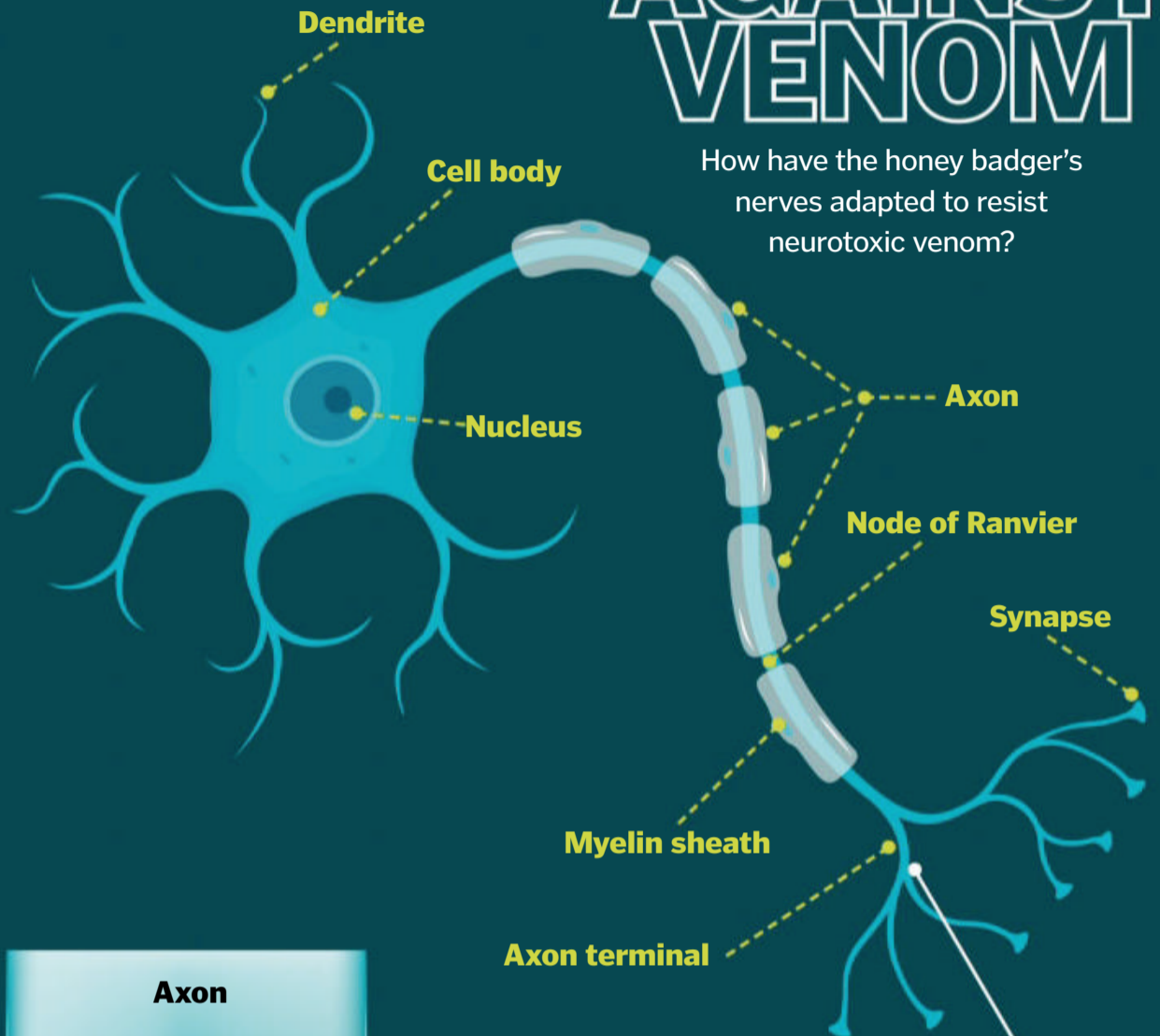

Neurotransmitter

These are the nervous system's molecular messengers, carrying information between nerve cells.

Dendrite

At the head of nerve cells, these protrusions are where neurotransmitters are received from adjoining nerve cells.

Axon terminal

Several of the protrusions at the end of a nerve cell deliver neurotransmitters to an adjacent nerve cell to pass a signal from the brain along the body.

Neurotoxin

Injected through the bite of a snake, these toxins travel to a synaptic cleft where nerve communication is carried out, to bind with the nerve receptors and prevent the signal being carried forward.

Mutation

In antivenom animals such as the honey badger these receptors have a mutated shape that still binds with neurotransmitters, but is unable to bind with the neurotoxin.

Receptors

Channels are opened by neurotransmitters to allow sodium into a nerve cell to carry the electrical communication through the system.

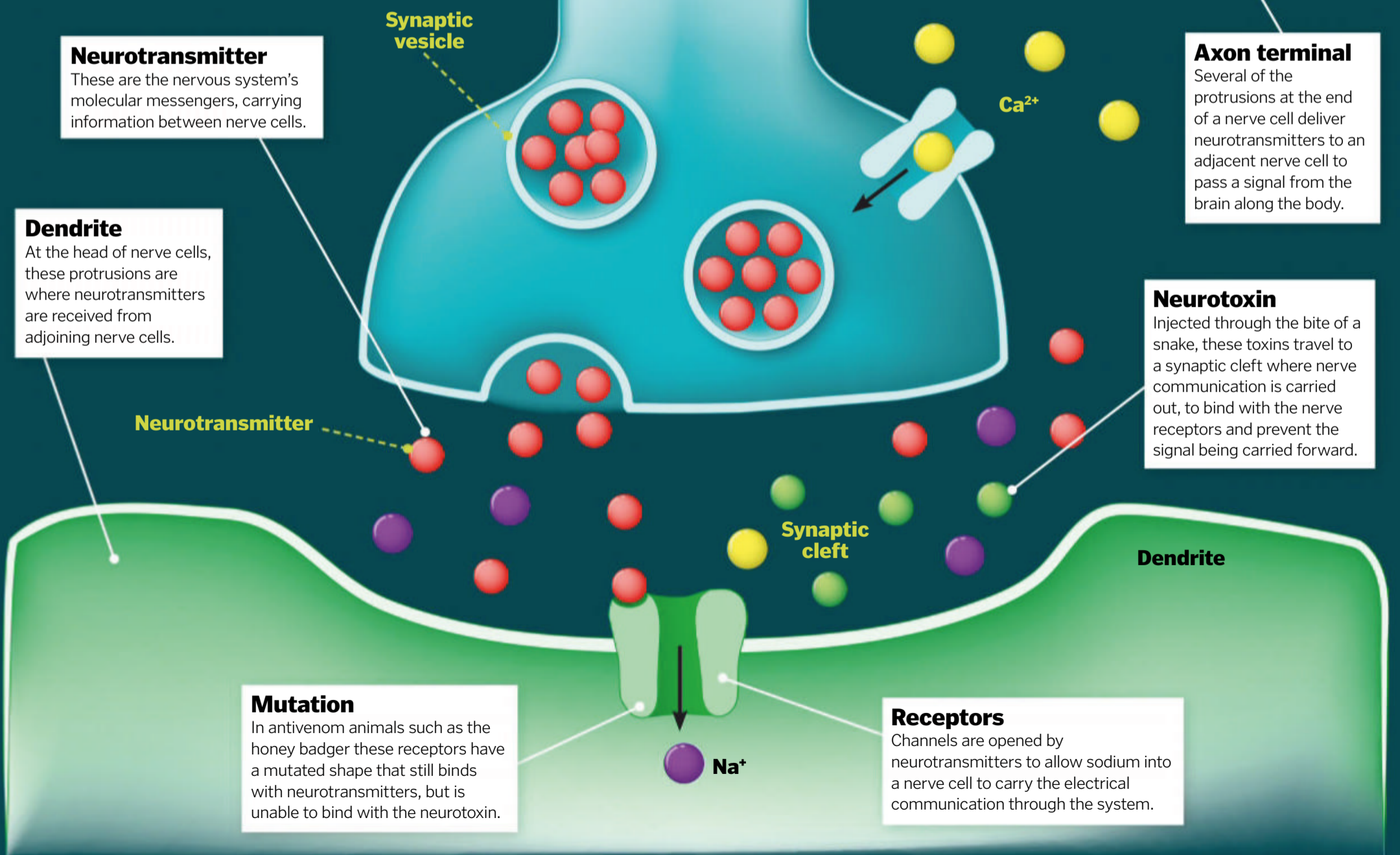

immunising it to their paralysing effects. The mongoose is not alone in its fight against the forces of neurotoxins: honey badgers, ground squirrels and even hedgehogs are among some of the mammals able to endure an otherwise fatal dose of neurotoxin from the fangs of a snake.

The North American opossum is also well-equipped for a battle in the bloodstream with the ability to neutralise the venom of around 12 species of venomous snakes. The western diamondback rattlesnake, for example, is one such species. This snake's particular brand of toxin is a hemotoxic venom, infiltrating the bloodstreams of their prey or aggressor, hijacking its blood cells and destroying their internal organs and circulatory system. The opossum, however, has a blood cell bodyguard in the form of a chain of amino acids in its blood that are able to neutralise invading venom.

Arguably the world's most venomous species, the box jellyfish is able to disable and kill many living creatures in seconds. With each tentacle equipped with 5,000 stinging cells, these formidable creatures don't seem like potential food, yet leatherback turtles feast on jellyfish almost exclusively. Unlike the other mammal

antivenom members, leatherback turtles have a physical adaptation to defend against one of the world's most venomous jellyfish. Lining its thick oesophagus that leads towards its stomach are continuous rows of inward-facing papillae, or protrusions. Made from hard keratin, the same material found in fingernails, the sting of a jellyfish is rendered useless.



Built-in blood bodyguards prevent an opossum's blood from being affected by venom

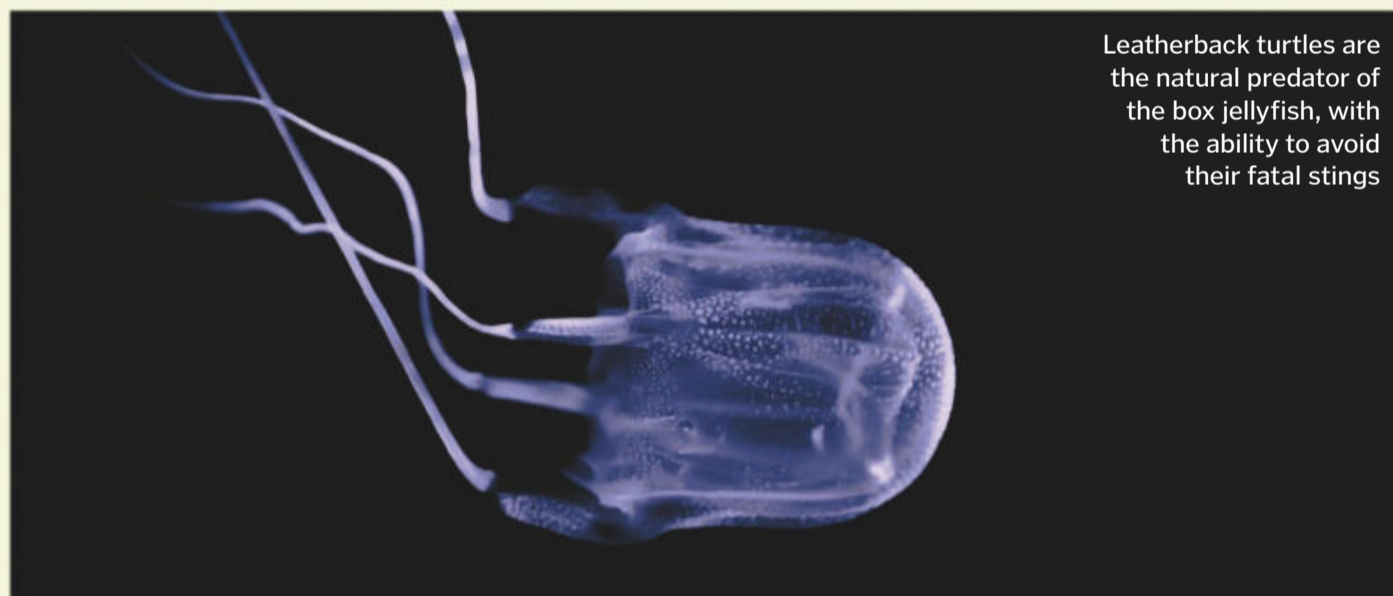

Leatherback turtles are the natural predator of the box jellyfish, with the ability to avoid their fatal stings

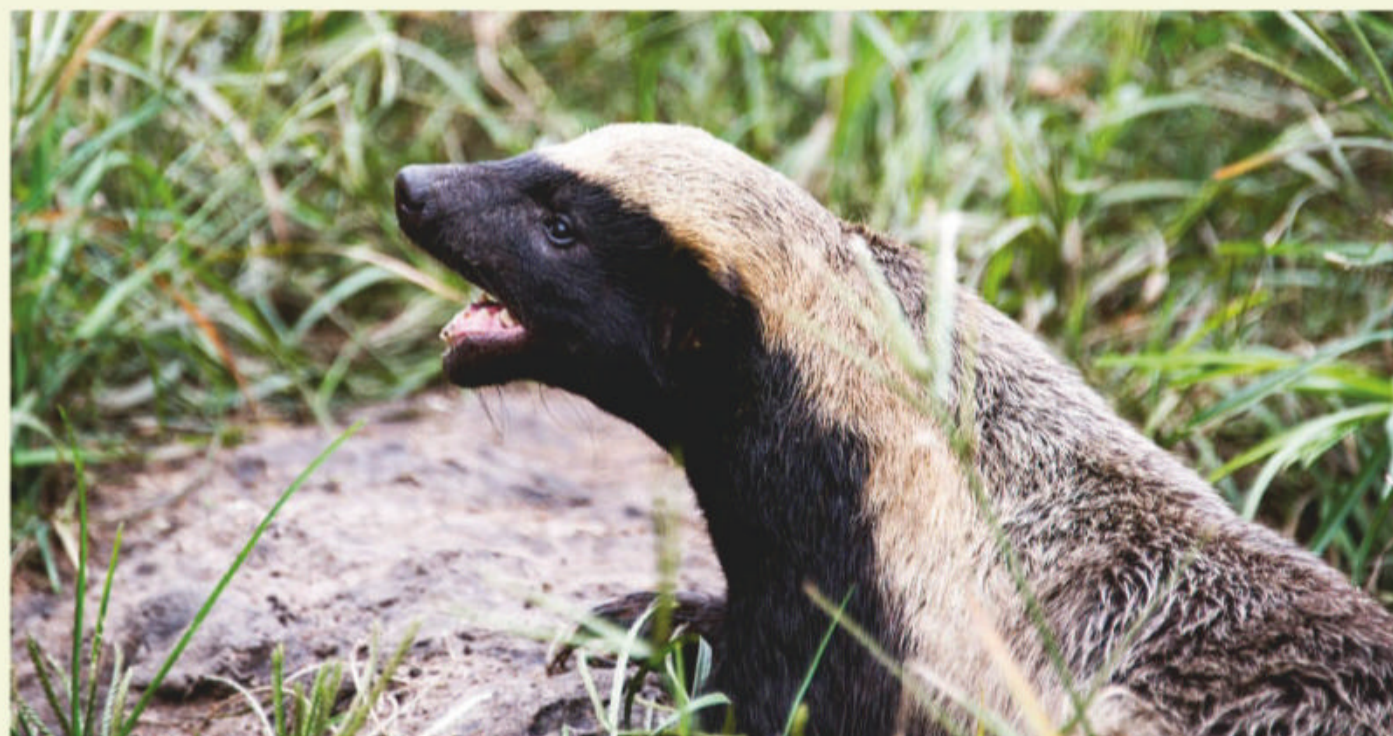

Honey badgers have evolved an immunity to the neurotoxic venom of snakes

Q&A

Q&A with venom expert Bryan Fry



An associate professor at the school of Biological Sciences, University of Queensland, as a biochemist and molecular biologist Bryan has spent his

career expanding our understanding of venom and its evolution.

How have venomous snakes evolved immunity to their own venom?

This has been accomplished through a myriad of mechanisms ranging from structural modifications of neurological receptors through to circulating factors that neutralise toxins.

Can venom of snakes from the same or different species affect one another?

They will be immune to venom from snakes that have similar venoms, like those within the same species or from related species. However, some species have venom that varies dramatically across the range, and therefore the immunological cross-reactivity would be much less. Such as the Southern Pacific rattlesnake in California, where some populations are neurotoxic and others coagulotoxic [blood clotting toxins]. Similarly, some species have venoms that change as they age, reflective of young snakes specialising on different prey to adults. Again the degree of immunological cross-reactivity would be affected by this. For example, Australian brown snakes are neurotoxic and specialise on lizards as young snakes, but are coagulotoxic and specialise on mammals as adults.

How can our understanding of animal venom immunity help produce antivenom treatments in humans?

It can help us understand the evolutionary patterns for venom diversification, which in turn gives us a better prediction of potential clinical effects and antivenom problems.



Queen bees begin a new colony in spring, accelerating the growth of flowering plants through pollination

Sprouting through the snow, fragrant crocuses are some of the first flowers to bloom in spring

Alaska

Spring starts late in the US' largest state. It starts out cold and wet, and is a time of intense competition among emerging animals. Forest fires are not uncommon in late spring. Recently burned areas grow morels, mushroom-like fungi that are a highly sought-after.



Hawaii

Humpback whales take refuge in the warm waters of the southern Pacific during winter. Migration begins in spring. These whales escort their calves over 4,800 kilometres to their northern feeding grounds. Mothers have not eaten since the previous summer, so spring can't come soon enough for them.



Sahara Desert

Sandstorms are common in spring and can be extremely dangerous. Dust can even spread to neighbouring continents when sediment is swept away in air currents. However, as sand-filled air moves, it prevents the formation of cloud, thwarting springtime storms.

Why spring happens

What happens when winter begins to fade and spring brings the promise of regeneration?

Spring occurs as a result of the planet warming up after a plunge in the temperature during winter. There are several biological indicators that signal the season's arrival. Plants start to bloom, hibernating animals resume their activities and soilborne microfauna (tiny organisms in the ground) begin to thrive. Snow-covered areas begin to see the light of day, and melted snow feeds into streams and rivers. In coastal areas, snowmelt trickles into the ocean after picking up nutrients during its journey. This enriched water causes enormous plankton blooms, which in turn support the rest of the sea's ecosystem.

The timing of spring is affected by a number of factors. A region's latitude and longitude determine when spring kicks in,

along with the weather during that particular year. Countries in the southern hemisphere experience the opposite effects to the northern hemisphere. When flowers begin blossoming in Europe, leaves start to fall from the trees in Australia.

Spring has no fixed arrival date - it happens when the conditions are right. Its arrival has a plethora of effects on Earth's organisms. As plants shoot up from the ground, food availability increases. Herbivores get the opportunity to forage, while carnivores lie in wait for their prey. Sunlight hours extend, rain enriches the ground, and a huge number of species give birth to their young. The planet transforms before our very eyes every year, breathing new life into the Earth.



Chile

Spring days are long and warm. Exotic flora sprouts all over the country, even in the driest desert on Earth. The Atacama Desert can transform from a dusty wasteland to a lush, green environment with vibrant flowers.

EQUATOR



Brazil

The peaks of vegetation and animal biomass occur in Brazil in spring. This is a busy time for Brazilian farmers. Brazil is the world's leader in coffee production, producing over 50 million 60-kilogram sacks every year.

Leaning into the seasons

Earth tilts at 23.5 degrees, which is thought to be the result of a planet colliding with ours 4.5 billion years ago. Scientists think the rubble left by the crash became the Moon.

Because of its tilt, Earth is at an angle rather than directly in line with the equator. The diagonal motion of the Sun is described as 'ecliptic' and varies the amount of radiation that hits our planet. Earth spins on its axis, which always points in the same

direction, so different parts of the planet receive direct sunlight throughout the year.

The moment when the Sun's orbit intersects Earth's 'celestial equator' (an imaginary projection of Earth's equator line) is called an 'equinox'. During the spring and autumn equinoxes, night and day are 12 hours each. For the rest of the year sunlight directly hits one hemisphere and indirectly hits the other, creating a year-long climate pattern.



The summer solstice is the longest day of the year in the northern hemisphere

Arctic

After six months without sun, the North Pole enters spring around 18 March. Sea ice begins to split apart, while lakes and rivers start to thaw. Plants sprout and animals initiate a feeding frenzy. Arctic hares and foxes lose their white fluff in favour of dark camouflage.



Mongolia

Between the harsh winter and short, hot summer, Mongolian spring comes as a welcome relief. As the seasons change there is a surge of rain. Springtime flooding can last for weeks at a time, and up to 60 per cent of the country's annual runoff falls in spring.



Spring around the world

The season of new life presents itself differently in various places

"Spring has no fixed arrival date – it happens when the conditions are right"

Madagascar

This island off Africa's east coast does not really experience spring. There are only two seasons in this tropical region: dry and rainy, although the overall climate is subject to regular change due to nearby winds.

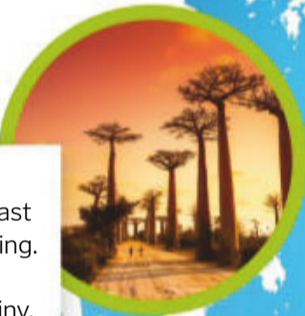

Australia

Being in the southern hemisphere, spring blooms around September here. It's a large country and the weather is a mixed bag, with dry heat in the north and lots of rain down south.



Antarctica

The South Pole is a different story to its northern twin. Their seasons happen at opposite times, so one is warming up while the other is freezing solid. Penguins have to be especially careful to make sure melted snow doesn't flood their terrestrial burrows.



5 FACTS ABOUT SPRING

1 Seasons creeping

A phenomenon known as 'season creep' is quickening the onset of seasons over time. Over 30 years, spring can be brought forward by an entire week.

2 Groundhog day

An American groundhog is supposed to be able to predict the onset of spring depending on the visibility of its shadow. Its accuracy, however, is only 36 per cent.

3 Birdsong booty call

Birds sing more in spring than any other season, in order to reproduce in time for eggs to hatch in summer. Males attempt to attract females with complex song.

4 Six seasons

Ecologists divide the year into more than four seasons for temperate climates: prevernal (March to May), vernal (May to June), estival (June to August), serotinal (August to September), autumnal (September to November) and hibernal (November to March).

5 Super soil

Forest soil contains upwards of 50 per cent of the ecosystem's organic carbon. Tiny organisms in the substrate recycle compounds, fertilising the soil ready for new plant growth.

The long sleep

Waking up is an automatic process controlled by the endocrine system. The thyroid cranks the metabolism up, while the pituitary gland is in charge of respiration and heart rate and allows an animal to build up fat to survive the winter. Rising temperatures are the trigger for hibernating animals to stir. It takes a lot of energy to warm the body up even by a few degrees.

Organisms in hot areas can enter a state of dormancy called 'aestivation' – the opposite of animal hibernation in cold environments. They aren't escaping the heat per se, but enter torpor (sleepiness) when the environment becomes too dry.



East African hedgehogs are nocturnal foragers that spend an entire season sleeping



What are atmospheric rivers?

This churning stream of water vapour flows through the air like rushing river rapids

Atmospheric rivers drive tropical water vapour towards Earth's poles. They form over oceans and are spurred forward by wind and high-altitude jet streams. There are around four passages of vapour in each hemisphere at any given time, and together these passages account for 90 per cent of poleward moisture movement. This warm vapour transit is a crucial component of the water cycle. It delivers essential rain and snow to temperate and polar regions from equatorial evaporation. However, atmospheric rivers can cause extreme rainfall, resulting in flooding, landslides and destruction of infrastructure. The force of an atmospheric river is determined by its moisture concentration and the strength of the wind. The strongest rivers are responsible for the most precipitation, which can sometimes even be life-threatening.

Each atmospheric river is led by a boundary between air masses, known as a front. There is cool, dry air ahead of the front, while the warm,

humid river swirls forward in a tight mass. The high-pressure cold air interacts with the low-pressure warm atmospheric river, forcing it upwards. As it rises, the temperature drops and the vapour begins to condense, resulting in precipitation. As atmospheric rivers can be thousands of kilometres long, rain or snow may continue for several days.

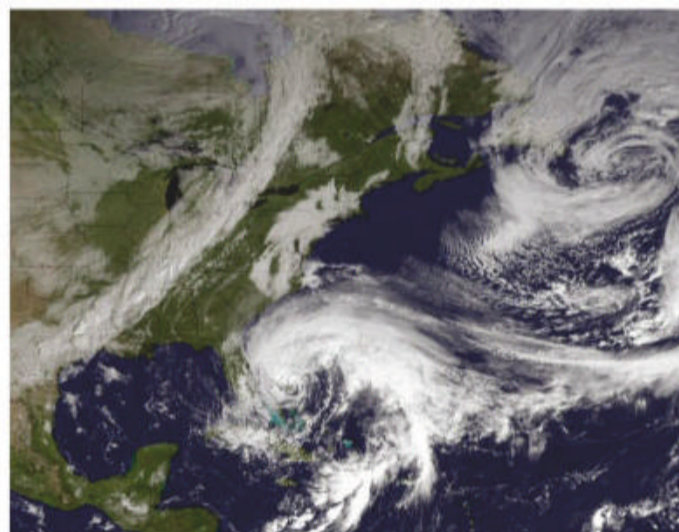

Ribbons of dense, warm water vapour slice through the sky to deliver water to the ends of the Earth



The US suffered 14 climate and weather events that cost over £760 million (\$1 billion) each in 2018

The western front

Between 30 and 50 per cent of the US West Coast's annual precipitation occurs in just a few atmospheric river events. One such occasion in 1861 brought 43 days of continuous storms to California. Thousands of people perished, along with a quarter of the state's cattle, and the knock-on effects caused the state of California to go bankrupt within six months. Since 1861, California's population has swelled from around 380,000 to approximately 40 million. A storm of that magnitude today would prove to be absolutely devastating.

The power of an atmospheric river is undeniable, and research indicates that their activity is on the rise thanks to climate change. Rising global temperatures increase the vapour-holding capacity of a skyborne river. Since 1948 there has been an increase in days with rain or snowfall from atmospheric rivers. Increasingly regular storms are hitting Washington, Oregon and California. If action is not taken to limit climate change, atmospheric rivers will continue to cause damage and even claim lives.

© Getty/NOAA

An atmospheric river's journey

How water from the ocean evaporates and disperses across the planet

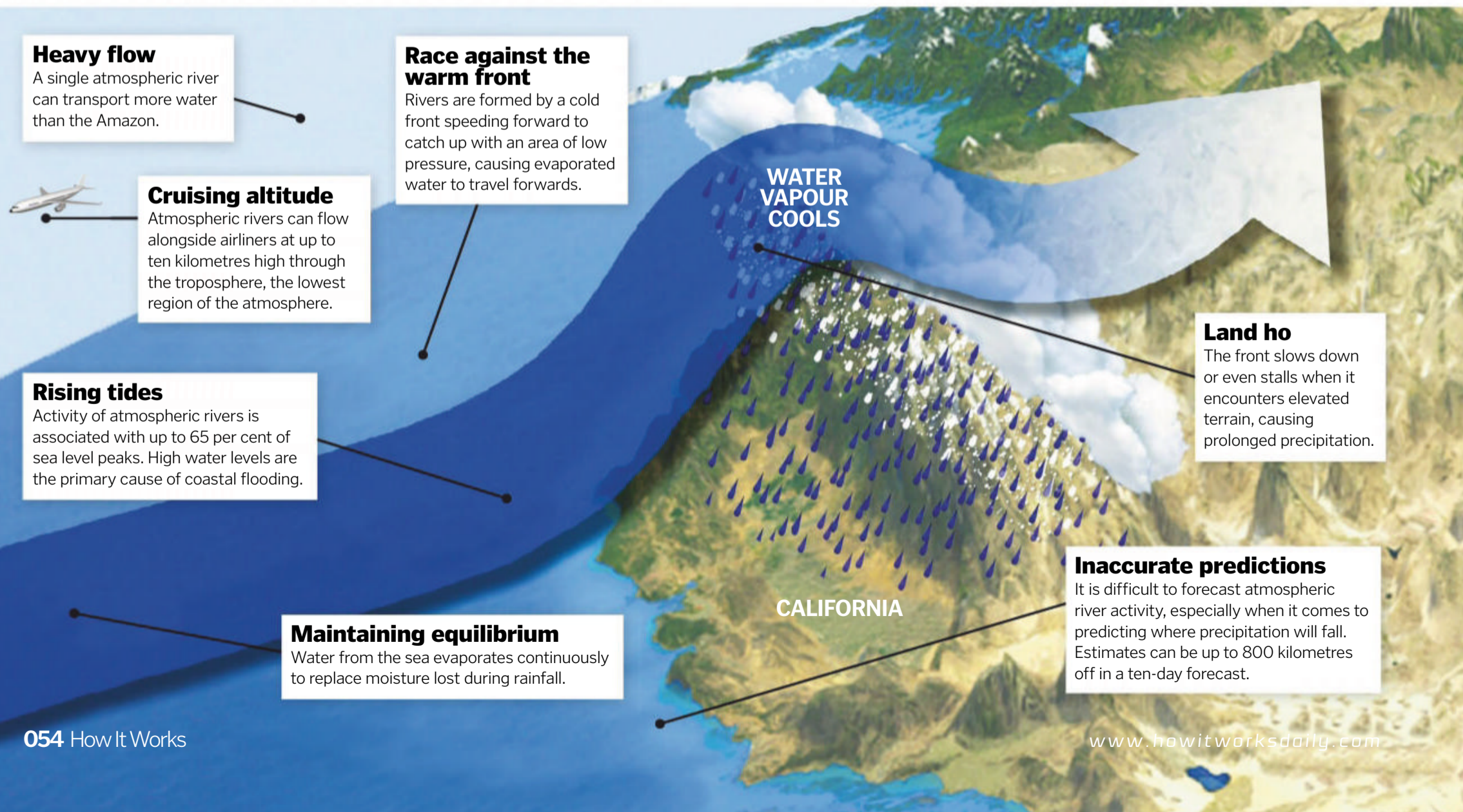

DISCOVER THE PAST!

www.historyanswers.co.uk



Available from all good newsagents and supermarkets

ALL ABOUT HISTORY

ON SALE NOW

The Rise Of Sparta • At Queen Victoria's Deathbed • Civil Rights Heroes • Stealing The Mona Lisa

CRUCIAL EVENTS



ILLUSTRATIONS



GREATEST BATTLES

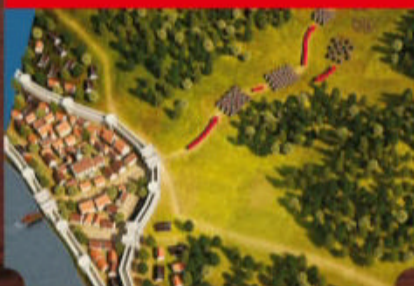

KEY PEOPLE



PAST CULTURES

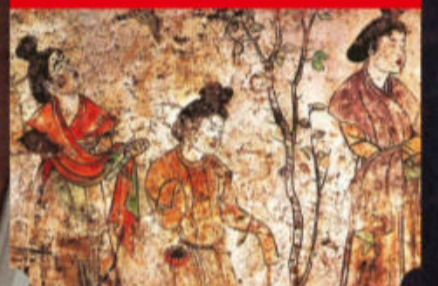

BUY YOUR ISSUE TODAY

Print edition available at www.myfavouritemagazines.co.uk

Digital edition available at www.greatdigitalmags.com

Available on the following platforms



[facebook.co.uk/AllAboutHistory](https://www.facebook.com/AllAboutHistory)

twitter.com/AboutHistoryMag

**Sight**

As typically nocturnal hunters, tigers have excellent sight to detect their prey's movements.

Hearing

A tiger has the ability to hear sounds up to 300-500Hz, along with low-frequency infrasound that can't be heard by the human ear.

Anatomy of a peerless hunter

What makes the tiger one of the planet's most powerful predators?

Bite

With the largest canines of all the big cats – nearly eight centimetres long – a tiger's mouth is filled with 30 razor-sharp teeth, with a bite force of over 1,000 PSI – more than five times a human's bite pressure.

How tigers hunt

These killer cats take down their prey solo, without any help from a pack

Poised between the blades of the tall grass in the savanna, a feline body is crouched like a coiled spring, ready to pounce on a passing deer. Within seconds this striped assassin leaps from its grassy hideout, delivering a fatal blow to the back of the deer's neck before feasting on its victim's flesh.

Tigers are notorious stalkers, a technique that has served them well in the wild. Typically tigers make a kill once a week, and they have the ability to consume up to 40 kilograms of food in a single sitting. With a diet almost exclusively made up of meat, they have fine-tuned hunting skills, placing them at the top of the food chain as an apex predator.

Tigers will tentatively stalk their future meal until they're within six to nine metres away. Once in range, tigers target their prey's neck, which severs its spinal cord. Larger meals may also require a fatal bite to the throat to drag them to the ground. As capable swimmers, tigers also utilise surrounding water to drag down and drown resistant prey. Once the struggle is over,

tigers will move their catch under cover to enjoy in peace without interference from scavengers.

Usually hunting at night, tigers possess excellent eyesight – six times that of a human's night vision. Unlike their lion cousins, adult tigers do not hunt as a collective pride, preferring to hunt solo. Though this may reduce the likelihood of a kill, the meaty rewards are reserved solely for the hunter.



Tigers primarily hunt large ungulates such as deer and wild boar

Claws

Retractable claws in a tiger's paw grow to around ten centimetres long, with each paw housing four normal claws and a specialised claw called a dewclaw.

Like a human fingerprint, no two tigers have the same stripe pattern



Hunting in captivity

With more tigers living in captivity than in the wild (up to 7,000 in the US alone, compared to around 3,890 wild individuals worldwide), zookeepers have come up with different ways to satisfy tigers' desire to hunt. As introducing live prey into enclosures is strictly prohibited, zookeepers aim to mimic aspects of prey by artificial means. The Smithsonian's National Zoo in Washington, US, has a novel approach to allowing the resident tigers to display their predatory behaviour. Large, sturdy balls known as 'boomer balls' are used for tigers and other big cats to chase and interact with like live prey. Other methods of hunting enrichment include animating animal carcasses or creating prey species out of cardboard for tigers to stalk and hunt.



Tigers will stalk and hunt boomer balls that are tough enough to withstand their bites

Speed

To chase after its prey, a tiger can run in bursts of up to 65 kph.

Stripes

The iconic striped appearance breaks up the body, disguising the tiger among the grass.

Tail

Typically around one metre long, the tiger's tail can be used for balance when pursuing prey at high speeds.

Pounce

A tiger is able to leap forward as much as ten metres to catch its prey.

Hunting school

Tigers are not born with the exact knowledge of how to expertly take down fleeing food - that lesson is learnt from their mother. At the beginning of a tiger's life, cubs feed on their mother's milk, before moving onto the meat she catches. Once the cubs are around eight to ten months old they will start to hunt with their mother, spending the next year or two learning how to hunt from her example. The mother will play with her cubs in order to teach her offspring useful life skills like pouncing and stalking. She will take her cubs on hunting expeditions to showcase how a kill is made, in the hope that the cubs will

mimic her technique. Once their training is complete, the next generation of hunters will leave their mother's side and seek their own territories in which to hunt for prey.

Tiger cubs stay with their mother for around two years, learning how to hunt as they grow



Estimates suggest that every tiger consumes 50 deer-sized animals each year





NEUTRINOS TAKE
TWO PER CENT OF
THE SUN'S
ENERGY AWAY
FROM ITS
SURFACE

INSIDE AN ATOM SMASHER

Take a trip into a particle accelerator and discover the experiments that are solving the mysteries of the universe

Words by Jack Griffiths

Deep underground in the US Midwest, groundbreaking projects are utilising advanced particle technology to examine tiny subatomic matter. From a subterranean facility, powerful particle pulses are sent across states every second at almost the speed of light. The reason? To try and find out why we exist. Welcome to Fermilab.

The Fermi National Accelerator Laboratory (Fermilab) near Chicago, Illinois, is the US' premier laboratory for high-energy particle physics. It began operations on 15 June 1967 and it's one of 17 national laboratories managed by the US Department of Energy. Its staff are currently on a mission to locate and study mysterious particles called neutrinos.

Neutrinos are subatomic elementary particles, similar to an electron or proton, except they have less mass and no electrical charge. You can't see, feel, hear or smell them, but neutrinos are all around us. And they're passing through your body at a rapid rate – 100,000 billion of them every second actually, give or take.

Solving their mysteries could potentially increase our knowledge of the origins of matter. Neutrinos can't be seen with the naked eye, but

they could be vital to how the universe works. It's thought there were equal amounts of matter and antimatter (a partner particle with the same mass but opposite electric charge) shortly after the Big Bang that formed the universe. Then matter became much more abundant than antimatter, allowing for the formation of atoms, stars, planets and humans. The particle accelerators at Fermilab can send out both neutrinos and antineutrinos, their antimatter counterpart, so if a difference is found in how

neutrinos and antineutrinos behave, it may help to explain how the universe evolved to end up without antimatter.

Neutrinos are created naturally in huge nuclear reactions in the Sun, or when a star supernovas, but can also be made in nuclear power plants and using particle accelerators, like at Fermilab. To try and analyse these rare particles, various projects have been set up at Fermilab. The first was DONUT in the late 1990s, which was followed by MINOS in 2005. The NOvA Neutrino Experiment began in 2014 and upped the ante – it's one of the largest experiments of all time.

The particle accelerator used in NOvA fires a beam of protons to a detector more than 800 kilometres away in Ash River, Minnesota. The particles don't need a tunnel to travel through as they simply go straight through the Earth. This 14,000-ton detector is filled with light-conducting fibres that record the energy from neutrinos colliding with other particles. Along with the fibres, there are 344,000 cells of reflective plastic that are packed with 11

40,000
Cosmic rays go through the detector every second



The Fermilab laboratory is located on a 27.5 square-kilometre site



The main injector for the particle accelerator used in NOvA



Fermilab isn't the only place to have a neutrino detector – there's one at CERN and even one at the South Pole

**100
THOUSAND
BILLION**

Neutrinos shot from the Fermilab every second



The NOvA far detector is the biggest free-standing plastic object in the world

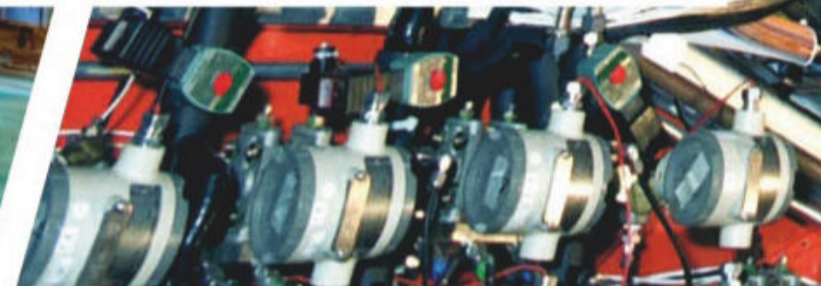

million litres of clear liquid that illuminate when particles come into contact. The facility uses cryogenic technology to keep the machines at -15 degrees Celsius, its optimum operating temperature. The detector is so gargantuan that a unique transport machine was required to move the 28 200-ton blocks that make it.

NOvA analyses how neutrinos change or 'oscillate' into different types. Neutrinos leave almost no trace and rarely interact with each other or other particles. The particle accelerator shoots protons, which then slam at very high energies into the target at Ash River. This creates shortlived particles that then decay to produce neutrinos. When neutrinos collide with other particles, the traces of the interactions are received by a detector, are examined by physicists and compared to previous statistics. Scientists are looking for trends in the data to decipher what neutrinos do and how they act.

"NOvA analyses how neutrinos change or 'oscillate' into different types"

One of the key breakthroughs that physicists have made is that there are different types, or 'flavours', of neutrino – each named after which electric-charged particle it collides with. Neutrinos are from the lepton family of particles, and like leptons there are three types – muon neutrinos, electron neutrinos and tau neutrinos. Electron neutrinos are produced when a neutrino slams into an electron, for example. As neutrinos blast through the beam, they change between the three types frequently. Starting off as a muon neutrino, they often oscillate to electron and tau neutrinos. Neutrino oscillation

is like a piece of fruit changing into a vegetable when you leave the supermarket, or this magazine changing into a book before you get home. Understanding why this happens will be key to understanding neutrinos.

Is there an endgame for NOvA? It has helped to increase scientific knowledge of neutrino oscillation and furthered the search for a fourth neutrino type. University College London and Sussex University in the UK are both collaborating with the project by helping to analyse the oscillations. NOvA will collect data until 2024, ten years after it was first switched on, when it will be replaced by an all-new project called DUNE.

Work on DUNE, or 'Deep Underground Neutrino Experiment', began in July 2017. The project will be the largest international science experiment to take place in the US. It will be the strongest particle beam in the world, sending



FERMILAB IS ALSO HOME TO MANY SPECIES OF BIRDS AND INSECTS, AS WELL AS COYOTES AND BISON

1.6KM OF SOLID ROCK WILL PROTECT DUNE FROM COSMIC RAYS

A technician examines a section of Fermilab's Collider Detector

particles 1,300 kilometres to the Sanford Underground Research Facility in Lead, South Dakota. Excavation for the Long-Baseline Neutrino Facility, which will house it, begins later this year and is planned to be up and running by 2022. The European Organization for Nuclear Research, or CERN, which houses the Large Hadron Collider, has its own, slightly smaller detector, which went online in September 2018. A second detector is also on the way.

DUNE will benefit from a significant upgrade to Fermilab's accelerators, with the Proton Improvement Plan II (PIP-II). PIP-II will provide a new particle accelerator that will generate a proton beam with 60 per cent more power than before. The mechanism will be made from superconducting materials with no electrical resistance, resulting in even more power for a

lower cost, and there will be more neutrinos to study than ever. DUNE will also have more sensitive detectors, using liquefied argon operating at -185 degrees Celsius. By 2026 the project will be fully operational.

Physicists at Fermilab will continue to study neutrinos to try and unlock the secrets they hold. Neutrinos can travel vast distances over the universe quickly, as few other particles, including those in magnetic fields, interfere with them. Because they are so difficult to locate, neutrinos could expose aspects of nature that are unknown to science, and potentially reveal the reasons why the universe is made of matter. We're only just beginning to understand the potential wonders of neutrinos and, as technology improves and our knowledge grows, there could be some startling revelations around the corner.

Q&A

Working on NOvA with Fermilab senior scientist, Peter Shanahan



Peter is one of Fermilab's 1,750 employees. The facility works with more than 50 countries on collaborative experiments.

How did you become interested in studying neutrinos?

Towards the end of my postdoctoral research on a different topic, the field of neutrino research had just had a breakthrough, with the discovery of neutrino flavour oscillations. I was excited by the potential for investigation in this newly energised field. I ended up getting a position at Fermilab to work on the first experiment to do that in the US, called MINOS, and I have been working on neutrinos ever since.

What's working with this tech like?

Most of the hands-on work is done by technicians, graduate students and postdoctoral researchers. This includes swapping out the occasional broken sensor or electronics card and using computers to analyse the data we take. As you get more senior, your work tends to get a bit more hands-off. We keep an eye on the systems that monitor the detector, and data-taking, including performing checklists to make sure everything is running and that we are taking good data.

What is most exciting about your job?

Our experiments often take decades to plan, build, operate and produce final results. Along the way there are many exciting milestones. For example, we do extensive simulations of a planned experiment. In that process, we see for the first time how well a new detector technology should be able to perform in tracking particles, based on detailed simulations of the detector and the particles going through it. The first time a new detector sees an unmistakable cosmic ray particle is always exciting. Then, your experiment produces new physics results – perhaps by providing a new measurement that is more precise than preceding ones, or by answering a question that no one had been able to answer before.



How to make a neutrino beam

Under the hood of the highest-intensity neutrino beam in the world

You spin me right round

The power is generated using a circular accelerator system, a set of rings 3.3km in circumference.

Break it down

In the graphite target, pions and kaons are produced from the energy of the protons slamming into neutrons and other protons.

Decaying away

In the decay pipe, the pions and kaons decay into even smaller particles called muons, as well as neutrinos.

Completing the process

The muons and neutrinos strike a beam absorber, which blocks the former but cannot stop the latter.

The neutrino beam

Now the beam is solely neutrinos, giving the best chance for their rare interferences with matter to be picked up by the detector.

Feeding the mechanism

A proton beam travelling at nearly the speed of light is directed into the mechanism.

Creating the beam

A magnetic focusing horn uses a magnetic field to concentrate the particles into a beam, eliminating interference from other matter.

It's getting hot in here

The powerful beam increases the temperature of the horn by 370 degrees Celsius, so a water and wind system keeps it cool.

DUNE uncovered

Inside the subterranean journey of neutrinos from Fermilab to Sanford

Straight through the Earth

No tunnel is required, such is the power of the moving particles, and the beam simply passes through solid rock.

The beam widens

As the beam heads towards South Dakota, it widens in the same way as a ray of light.

Interference from space

Neutrinos can also enter the detector naturally from the atmosphere and even from star supernovas.

Journey's end

Scientists analyse 3D images to locate neutrino tracks and potentially any previously unseen data.

Incoming neutrinos

A detector produces readings of the particles including traces of neutrinos.

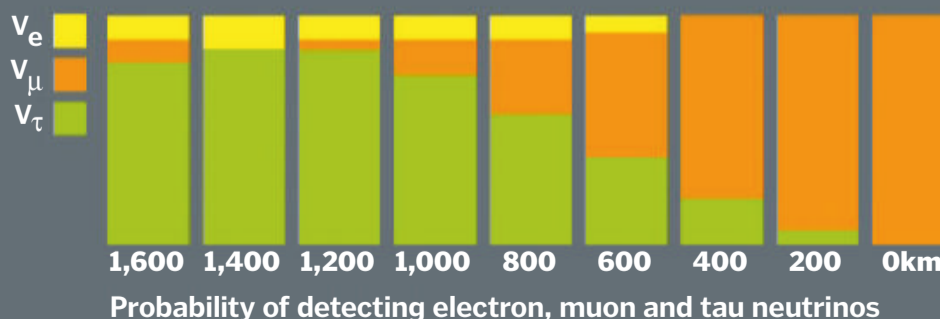
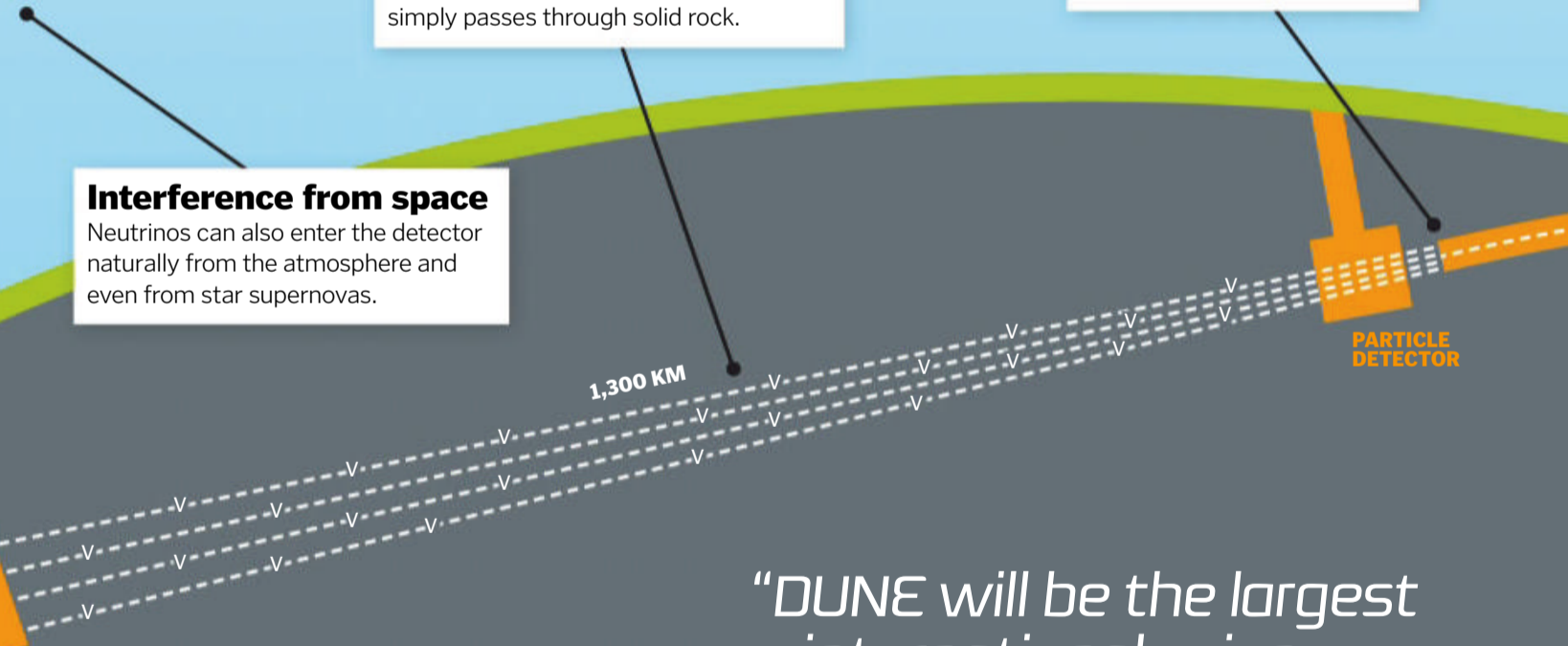

"DUNE will be the largest international science experiment in the US"



Incoming beam: 100% muon neutrinos

Tiny collisions

What happens when a neutrino smashes into another particle in NOvA?

Beam entry

The beam sent from the particle accelerator speeds through the Earth.

Impact

The interaction of particles including a neutrino causes a collision that is registered by the detector.

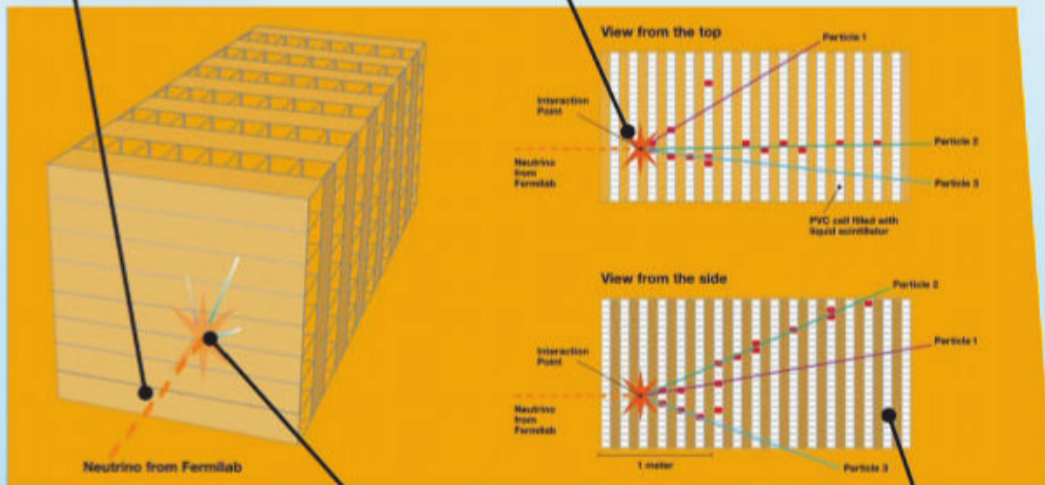

Noting the data

The data is picked up by electronics, which is then studied by physicists who will try to determine what the results mean.

Light me up

The scintillator in the detector lights up when it records a collision.



A Fermilab staff member working on the NOvA near detector

11,000
Sections of the
Minnesota
detector

**15 BILLION
YEARS OLD**
The estimated age of
many of the neutrinos
found in the NOvA
experiment



This chip controls a magnetron, which generates microwaves

**A NEUTRINO
TAKES JUST
0.0027 SECONDS
TO TRAVEL
BETWEEN THE
SITES**

Liquid argon at -185 degrees Celsius, that fills a cryostat that's used to test DUNE

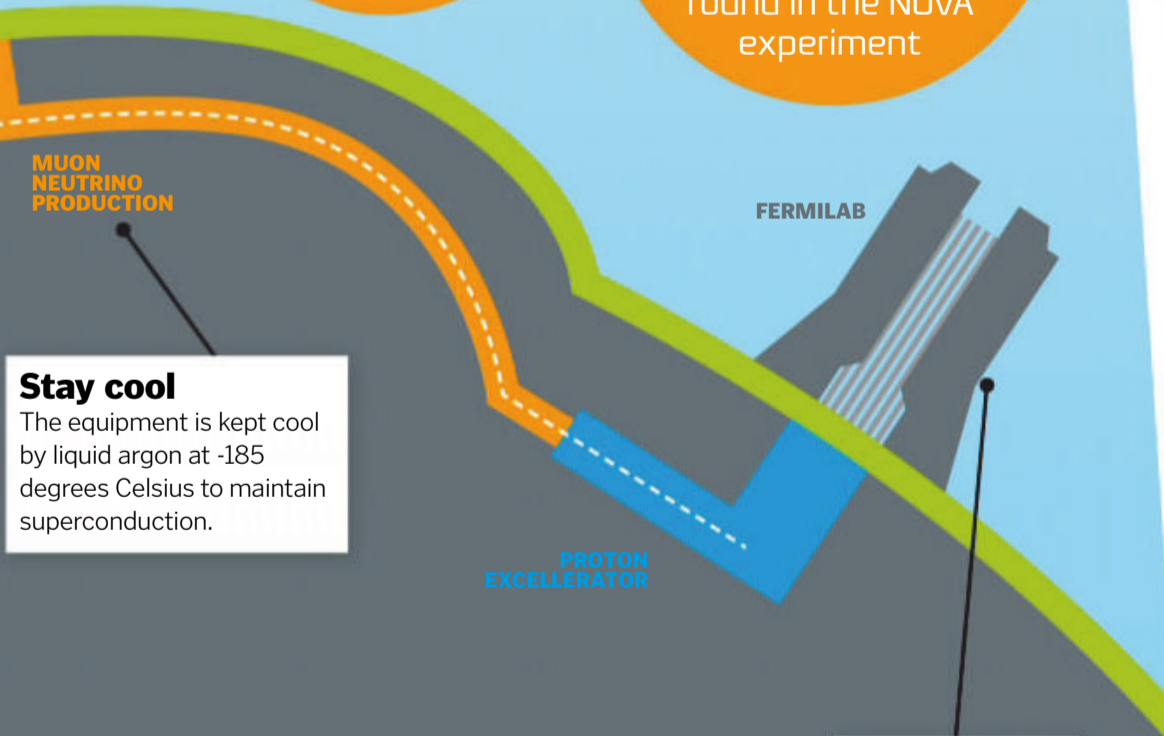

Stay cool

The equipment is kept cool by liquid argon at -185 degrees Celsius to maintain superconduction.

Start of the journey

The particle accelerator below Fermilab creates a particle beam that is fired a distance of 1,300km.

Learn more

WATCH NEUTRINO COLLISIONS LIVE
Visit nusoft.fnal.gov/nova/public to see live displays of the particle collisions, as recorded by the detectors at Ash River and Fermilab, a 360-degree video of the detector and more videos and graphics.



HEROES OF... SCIENCE

Cecilia Payne challenged conventional beliefs about the stars and their compositions

“Her results proved groundbreaking: the Sun was made up mainly of hydrogen and helium”

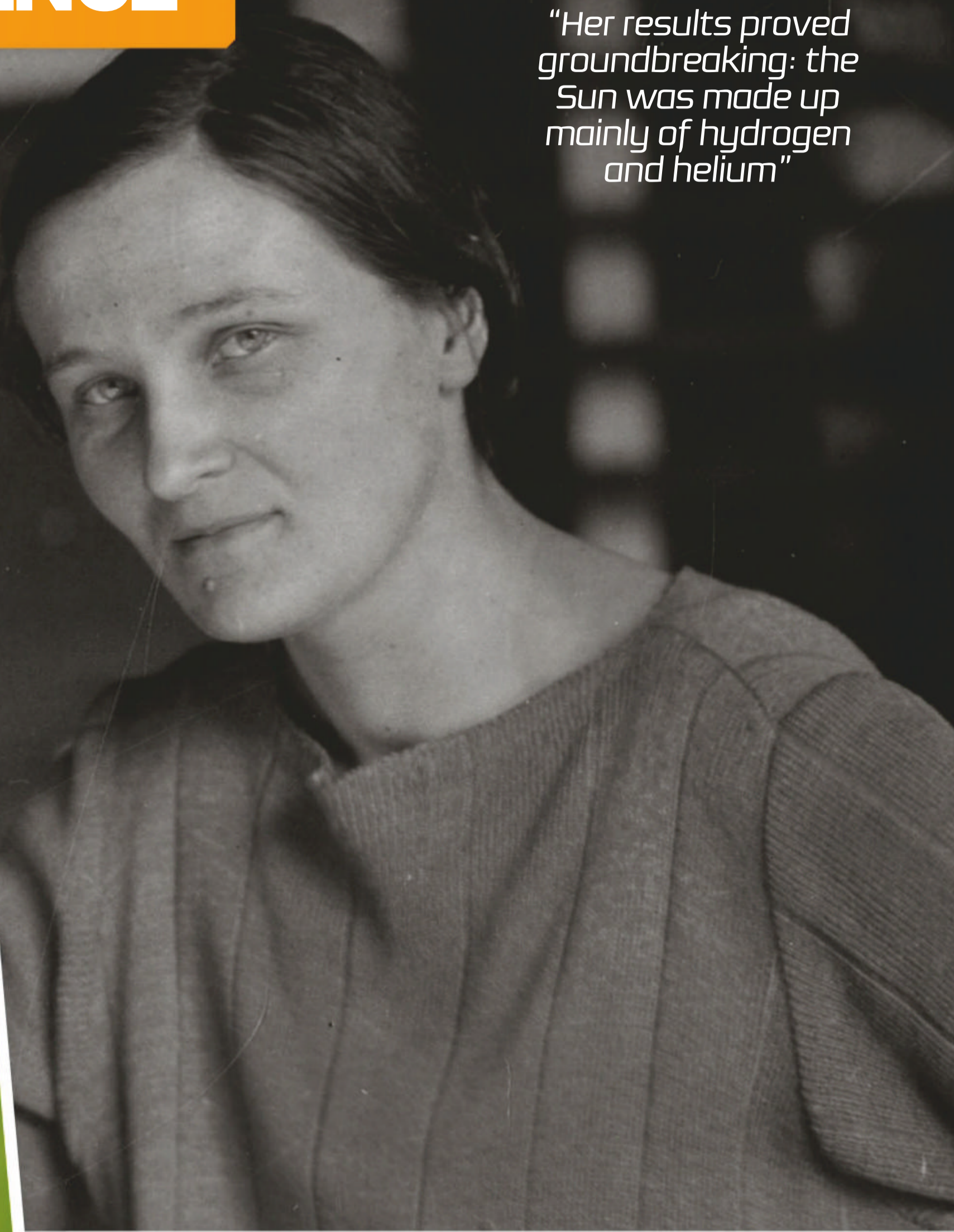

Cecilia would begin her love affair with science at an early age after seeing a bee orchid



A life's work

A journey to the stars

1900

Cecilia Helena Payne is born on 10 May in Wendover, England.

1904

Cecilia's father, esteemed musician, author and judge Edward John Payne, was found drowned in a canal. Her mother raises three children alone.

1908

Cecilia decides to become a scientist at the age of eight after noticing a bee orchid, a plant that resembles a bumblebee.

1919

The University of Cambridge awards Cecilia a generous scholarship, and she begins studying botany, physics and chemistry.

Cecilia Payne-Gaposchkin

The woman who changed our understanding of the Sun

Cecilia Payne was born in England to highly motivated and successful parents. Her father was a fellow of Oxford University, and her mother was a talented artist from an academically established German family. Still, for all the advantages she enjoyed in life, her gender would prove a hurdle the young woman would have to battle hard to overcome, particularly during her younger years.

She lost her father when she was four years old, but not before he had imbued in her a talent and passion for music. She would later go on to become a skilled pianist, and a tutor would one day implore her to continue with it professionally. However, it was science that stole her heart. Her mother had told her of a bee orchid, a plant that resembled a bumblebee, and upon discovering this Cecilia's mind was set on pursuing a career in science.

As a young adult she won herself a scholarship to study at The University of Cambridge's Newnham College, where she began studying botany, chemistry and physics. It was here that she was exposed to the superstars of physics – including Nobel laureates J. J. Thomson, Ernest Rutherford and Niels Bohr. After one lecture given by Arthur Eddington on the general theory of relativity, Payne lost sleep pondering its meaning. Her destiny had been set, and for the rest of her undergraduate degree she majored in physics and became absorbed in astronomy, her true passion.

Cambridge University, like English academic institutions in general in the 1920s, were conservative and chauvinistic establishments. So when Payne completed her studies she was not awarded an official degree on account of her gender. Knowing that her career in science would be stymied if she remained in the UK, she set sail for Harvard's Radcliffe College to work

with Harlow Shapley and Princeton's Henry Norris Russell, two of the most prominent researchers in her field at the time.

In just two years, Cecilia completed her PhD thesis on the chemical composition of the stars. Her results proved groundbreaking: the Sun was made up mainly of hydrogen and helium. But Russell, who disagreed with her assertions as they flew in the face of the accepted dogmas of the day, urged her to not trust her findings. She relented and followed his advice. However, Russell would, somewhat ironically, declare her findings correct four years later when he himself reached the same conclusion as Cecilia by different means.

Cecilia remained at Harvard for the rest of her academic career and grew into a huge success story. Her future husband found work at her observatory and helped her raise three children, and in the mid-1950s Cecilia made history again by becoming the first woman in her department to be promoted to a professorship.

She died of lung cancer in 1979 and was survived by her husband and children. She left behind a legacy as one of astronomy's most inspirational women.

THE BIG IDEA

The enlightening concept that sealed Payne's place in history

In the 1920s scientists thought that the Sun bore a similar elemental composition to that of the Earth, but conventional wisdom at the time grossly underestimated the proportion of hydrogen and helium – the two lightest elements – relative to the heavy metals. Cecilia would rectify this during her doctorate, as she scoured Harvard's vast library of star emission spectra to analyse not only the Sun but other, more distant stars for their chemical compositions. After solving a way to quantify the intensity of absorption lines emitted by stars, she was able to calculate the abundance of each element. To her amazement she discovered a gargantuan amount of hydrogen and helium relative to the other elements.



During her doctorate Cecilia discovered that the Sun was mainly composed of hydrogen and helium

IN THEIR FOOTSTEPS



Joan Feynman

Little sister to the eminent theoretical physicist Richard Feynman, Joan would go on to become an astounding astronomer in her own right, garnering fame for predicting the pattern of sunspots. But faith in her success was not always so easy to come by, as during

childhood her mother had informed her that women were not equipped to be scientists. All of this changed, however, when she read an excerpt from *Stellar Atmospheres*, authored by Cecilia Payne.



Helen Sawyer Hogg

Working directly under Cecilia Payne at Radcliffe College until 1931, Helen Sawyer Hogg later moved back to Canada and enjoyed an illustrious career surveying the stars. She ascended to the rank of professor at the David Dunlap Observatory and specialised in globular clusters,

forming an expansive catalogue of variable stars with her team. She also authored a popular column on astronomy in the *Toronto Star* for over 30 years, inspiring many others to pursue science.

1925

Cecilia Payne completes her PhD thesis in just two years, revealing that the Sun is composed mainly of hydrogen and helium.

1929

Cecilia's former supervisor, Henry Norris Russell, publishes a paper on the Sun's composition being mostly hydrogen. Cecilia is cited in his work.

1956

Cecilia Payne-Gaposchkin becomes Harvard's first female professor, and later the first woman to become a department chair.

1923

Cecilia leaves England to start her PhD at Harvard College Observatory. She becomes the second woman to join their graduate programme in astronomy for women.

1925

Under pressure from Shapley and Russell, Cecilia downplays her discovery. However, her work is released as a book entitled *Stellar Atmospheres*.

1933

Cecilia meets her future husband Sergei Gaposchkin in Germany. The two go on to work together at Harvard.



Adding fluorescent tags to mutant flies makes them easier to spot under the microscope

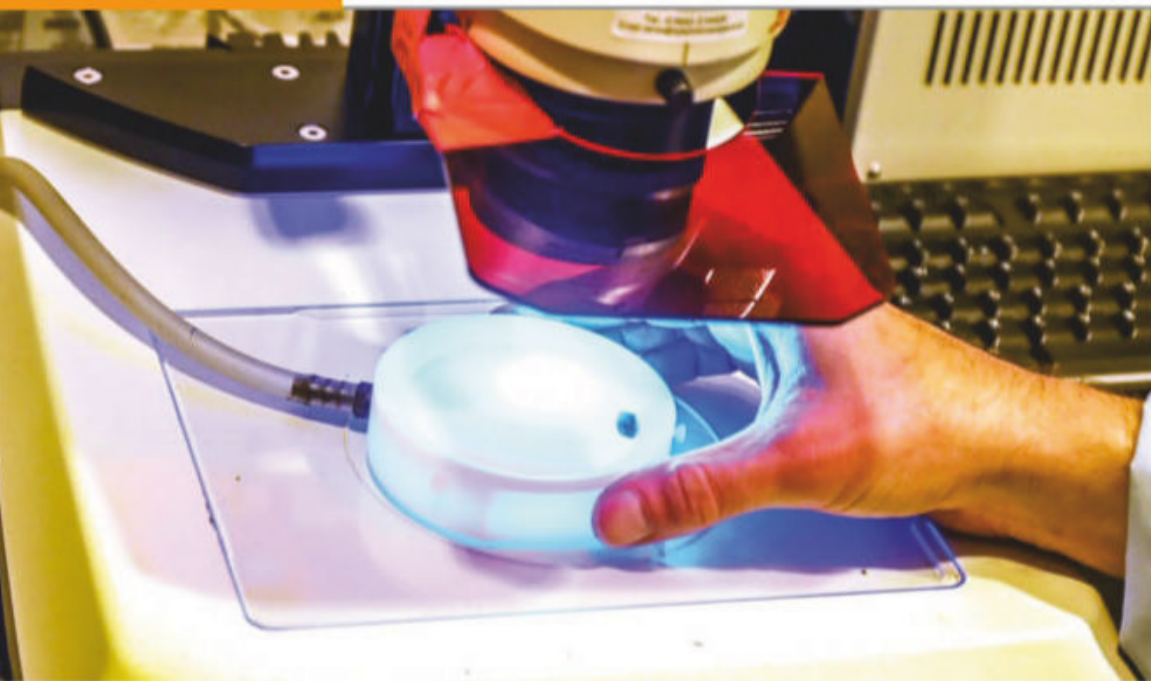

Finding cures for cancer

Can tiny flies help us to cure the world's deadliest disease?

Rotting fruit might seem like an unlikely place to find a cure for cancer, but the insects that feed on it are scientific superstars. *Drosophila* fruit flies measure just three millimetres in length, but they've already racked up six Nobel Prizes. Though they have around 30 times less DNA than we do, they share around 60 per cent of our genes, including those involved in causing diseases like cancer.

Scientists at the Francis Crick Institute in London are putting these similarities to good use. They use fruit flies to understand how cells work and what happens when they go wrong. Breeding fruit fly families for cancer research is a specialist task, so 'the Crick' has a dedicated Fly Facility staffed by expert technicians. They care for 1.5 million fruit flies, representing 8,000 different genetic strains. The flies have a generation time of ten days and their genes

mutate at lightning speed. Mutations are critical for tumour cell growth, so this makes them the perfect tool for carrying out rapid cancer research experiments.

The Crick's technicians can create flies with custom sets of genetic mutations. To do this, they cross-breed different types of flies and inject mutated genes into fly eggs with ultra-fine needles. Selecting and modifying the flies is a delicate task, performed under a microscope with the bristles of a paintbrush. The technicians examine the insects from all angles, looking for differences in their colour and shape. To make it easier to find the right flies, they add microscopic fluorescent tags to the mutated genes, making the insects glow. This helps the technicians to create flies with the perfect combination of genes so the scientists can get to work finding a cancer cure.

Q&A

Help the expert

Electron microscope expert Martin Jones needs your help to measure tiny structures inside cells



Jones is deputy head of microscopy prototyping at the Francis Crick Institute and develops hardware and software for image capture and analysis. His team generates more data than they can handle, so they're asking for your help processing it.

What is the Etch a Cell project?

Etch a Cell is a project we set up on the Zooniverse platform to help us overcome one of the major bottlenecks in our electron microscopy work, which is gaining understanding and new knowledge from our images. We often need to identify and measure tiny structures inside cells, using a process called 'segmentation'. Etch a Cell asks volunteers to help us do this for the nuclear envelope structure in lots of cells.

Why do you need help from volunteers?

In electron microscopy, new methods let us study 3D volumes by carefully slicing away tiny layers between images, some as thin as five nanometres. To do a whole cell at this scale might need hundreds or thousands of individual images. This stack of images can be captured overnight, but analysing them is less automatic. An overnight acquisition can take days, weeks or months for a small team of experts to analyse. By combining contributions from non-expert volunteers, we can get results that are as good as an expert's to use to train machine learning systems to do it automatically in the future.

What will you do with the data?

Once we've quantified the shape of the nuclear envelope in lots of cells, we can apply that knowledge to biomedical research. We also have a grander aim, to use the same techniques to study as many different structures in the cell. Since we work with many research groups in the institute, answering questions about different structures, we'll probably never run out of data, and our team of citizen scientists can help us extract many important pieces of information.

Digital drugs and virtual tumours

Crick scientist Paul Bates heads a team of researchers trying to stop cancer from spreading. It's the deadliest part of the disease, so a breakthrough here could be game-changing. Fruit fly research may be faster than research on slower growing animals like mice, but a cure for cancer can't come quickly enough. To speed up the science even further, Bates has gone digital. His team of computer scientists grow virtual tumours and give them hundreds of different digital drugs. Using a combination of simulation, machine learning and artificial intelligence, they can test new treatments much faster than biologists. In reality though, tumours are much more complicated than the simulations, so the results still need confirming. When a virtual drug looks promising, the team passes the data to the scientists in Crick's biology labs for further testing. They can then try the same experiments in the real world.



The Crick's Cell Services team grow cancer cells to test virtual predictions

Under the microscope

The Crick's most powerful microscopes use high-energy electrons to see inside cancer cells

Condenser lenses

A set of electromagnets force the electrons closer together, supercharging the beam as it passes through.

Objective lenses

Another set of electromagnets focus the electron beam onto the sample, a bit like the glass lenses in a normal microscope.

Specimen

The sample scatters the electron beam, absorbing and reflecting the particles in different directions.

Specimen holder

A copper grid conducts heat away from the sample and stops it getting too hot.

Specimen exchange chamber

Samples enter and exit the microscope through this specialised airlock.

Vacuum manifolds

Pumps remove the air from the inner workings of the microscope. This stops the electron beam bumping into gas particles.

Electron gun

High-voltage electricity energises a stream of electrons, shooting them downwards in a powerful beam.

Control dials

One dial controls the sample stage while the other changes the size of the beam.

Electron detectors

Detectors pick up electrons scattered by the sample and send the patterns to the screen as an image.

5 FACTS ABOUT THE TEAMS BEHIND THE SCENES

1 Fly Facility

The Fly Facility cares for 1.5 million fruit flies, all belonging to the genus *Drosophila*. These hungry insects consume a staggering 10,000 litres of food every year.

2 Cell Services

The Cell Services team looks after a frozen library of more than 6,000 different types of cell. They thaw them on-demand, bringing them out of suspended animation, ready for experiments.

3 Glasswash

The Glasswash technicians keep the Crick's equipment squeaky clean. Every year, they wash and sterilise more than 750,000 beakers, flasks and tubes.

4 Engineering

The Crick's engineers specialise in designing, building and repairing scientific kit. Not only do they mend around 3,000 items a year, they also make custom electronics for new experiments.

5 Microscopy

The microscopy team prepare cells and tissues for imaging with light or electron microscopes. They manipulate the tiniest of samples with a human eyelash glued to a cocktail stick.



A technician prepares fruit flies for genetic microinjection

Learn more

Meet the technicians and engineers working to find a cure for cancer at *Craft & Graft: Making Science Happen*. This free exhibition is open from 1 March until 30 November 2019 at the Francis Crick Institute in London.



What is a mouth ulcer?

How these common but painful sores form and develop

They're the mouth irritations that can make eating a meal unbearable, but the cause of mouth ulcers or canker sores is still relatively unknown. At least 20 per cent of the population is affected by mouth ulcers, and they vary in severity – these sores can appear as minor ulcers normally less than five millimetres, while major ulcers can stretch one centimetre in diameter. You can also have several ulcers clustered together to form large irregular ones known as Herpetiform ulcers.

There are two ways they can form and many occur as a result of trauma, such as biting your lip or cheek, or burning your mouth. However, the second form, known as recurrent aphthous stomatitis (RAS), has been linked with a whole host of conditions. Recurring sores can be due to bacterial infections, immune disorders, stress and smoking. Genetics also plays a large role in the likelihood of their repeated occurrence. Around 40 per cent of sufferers have a family history of experiencing ulcers, and this is

thought to be linked with the increase of a particular antigen that the body produces, potentially causing the RAS.

Ulcers typically heal after a few weeks, though those who suffer with RAS may experience them repeatedly. An ulcer lasting more than a few weeks could be linked with oral carcinoma, a form of mouth cancer.



Mouth ulcers – or canker sores – are caused by damage to the lining of the mouth

Sore stomach

Ulcers can form in several locations around the body, though a particularly painful place for them to be is in the stomach. Rather than a pustulous lump, a stomach (or peptic) ulcer is a hole that has formed in the lining of the stomach. This lining is biologically designed to withstand the low pH level due to strong stomach acids, but when this environment becomes too acidic for too long, ulcers can form. Other factors such as bacterial infection, alcoholism or the regular use of some anti-inflammatories can weaken the stomach lining, leaving it at risk for ulceration. Though they can occur at any age, those aged over 60 years are most susceptible to peptic ulcers, particularly men.



A peptic ulcer can develop in the lining of the stomach as a result of a poor diet or alcohol abuse

Formation of a canker sore

Most types of mouth ulcer usually have a relatively short life

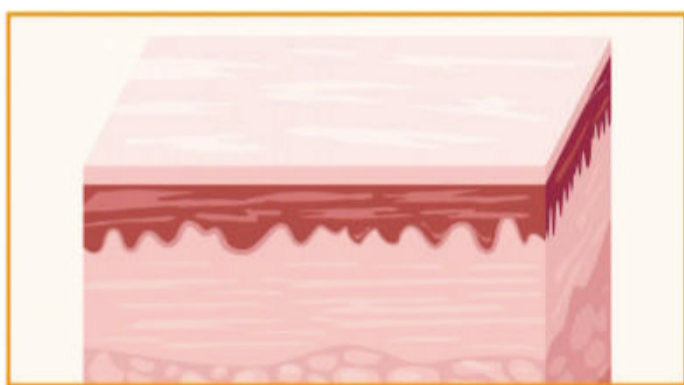

Healthy tissue

The healthy oral skin is comprised of several layers, known as the oral mucosa, which is the first physical defence against damage.



Trauma

Once the mucosa has been damaged, inflammation occurs at the trauma site, determining the ulcer's size.

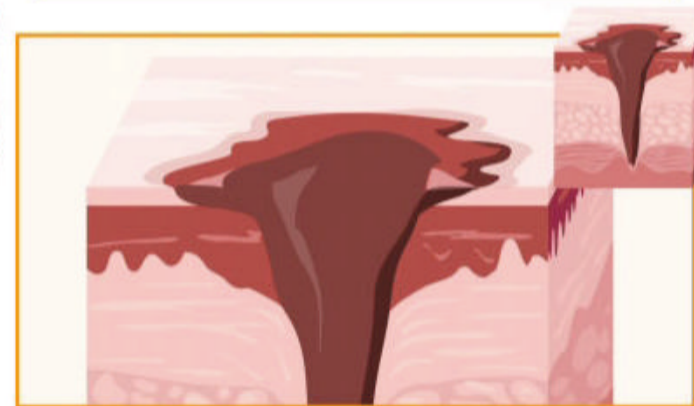

Cell death

Cells within the mucosa's layers will break down, creating the crater for the ulcer to fill.

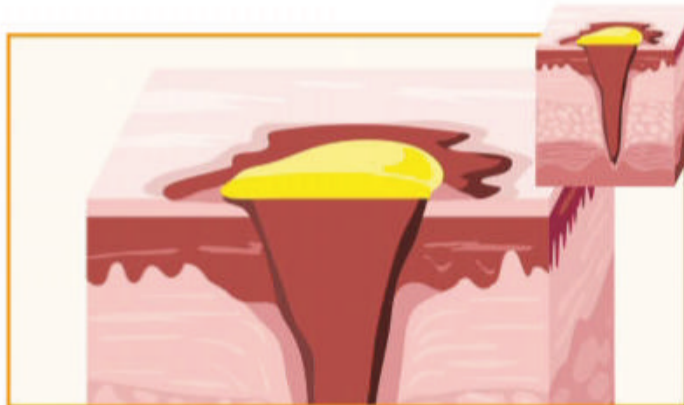

Ulceration

A cocktail of blood, tissue and bacteria fill the cavity, while a protein needed for healing wounds, fibrin, fills a membrane, giving the ulcer its typical white-yellow appearance.

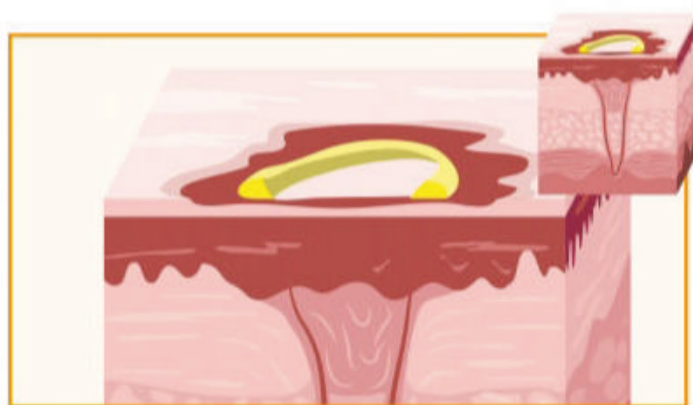

Breakdown

Once healthy tissue has been replaced within the ulcer's cavity, the fibrin membrane breaks down.

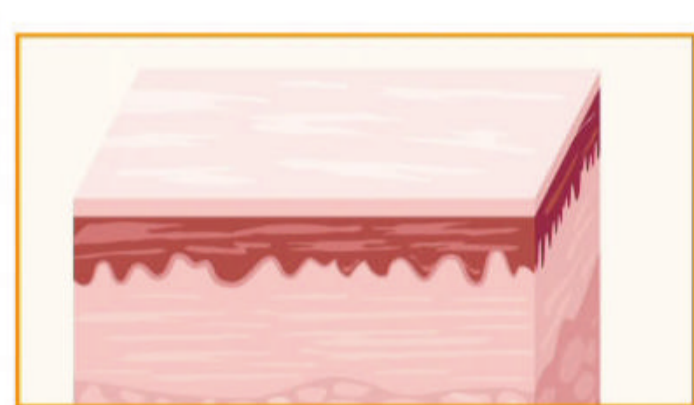

Healed

The oral mucous is now back to its original healthy state.

SATISFY YOUR HUNGER FOR KNOWLEDGE WITHIN THE PAGES OF THIS BOOK!

Find out everything that you need to know about stimulating science, trailblazing transport, transformative technology, spectacular space, humorous history and the extraordinary environment!



FUTURE



Ordering is easy. Go online at:

www.myfavouritemagazines.co.uk



Or get it from selected supermarkets & newsagents



ROEBOT

Words by **Scott Dufield**



Drones have been designed to act as both surveillance and support aids for soldiers on the ground

WARS

IN THE FUTURE OF THE FRONT LINE, THESE ARE THE MACHINES THAT WILL DOMINATE THE BATTLEFIELD

In November 2018, the UK's Ministry of Defence conducted the largest military robot exercise to date. Known as Exercise Autonomous Warrior, over 70 future technology examples were tested for their ability to support soldiers in conflict areas. More than 200 military personnel attended the event to test the suitability of these robots to join their ranks. From drone detectives to autonomous armed vehicles, **How It Works** travelled to a military base in Salisbury to discover which robots we might see on the front line in the future.

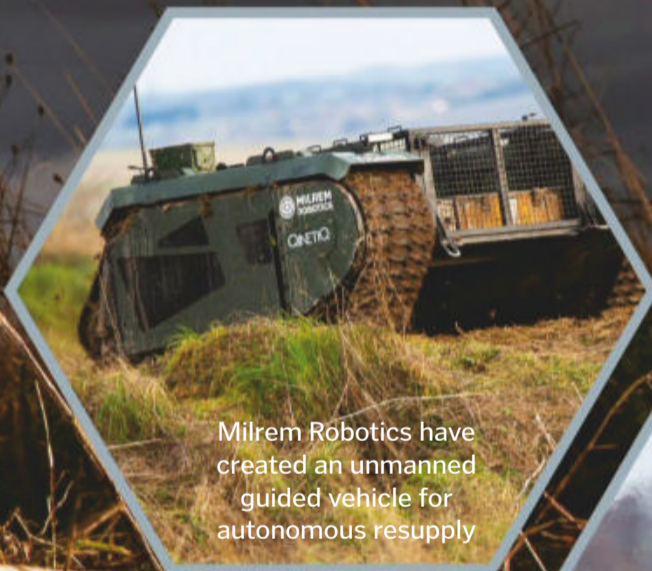

Milrem Robotics have created an unmanned guided vehicle for autonomous resupply



The Marionette control system removes the need for human operators and converts existing tanks into remote control robots





REMOTE CONTROL SOLDIERS

Human soldiers put their lives on the line in military conflict. However, collaboration between robotics engineers has resulted in the creation of mechanical soldiers to take some of the heat off their human comrades. A robot team known as TITAN Strike and Sentry, with the potential to reach areas inaccessible to foot soldiers, has been created by Milrem Robotics and QinetiQ. Strike is armed with a machine gun and cameras, while Sentry acts a guide, using sensors and cameras to track targets before its partner goes in on the offensive. Both vehicles can be controlled remotely or via a preprogrammed route. The modular base unit housing the artillery is known as THeMis and can also be used as a resupply device due to its autonomous abilities. Sensor and mapping technology enable the robots to travel between base and battlefield delivering ammunition, medical and resource supplies. Engineers have also created a way to hijack existing weaponry to create a new kind of robot – the British Warrior FV510 tank, which first entered service in 1988, has had a robotic overhaul with the Marionette universal system. Like a puppet on a string, this control system can be hardwired into the military tank, transporting controls of the mammoth vehicles to a patrol unit operated by soldiers several kilometres away.

SPY IN THE SKY

Drones have become a revolution in many different industries, but now unmanned aerial vehicle (UAV) developers Thred Systems has created a heavy-duty one designed to act as the

The Black Hornet PRS can fly two kilometres at speeds of up to 21.5 kilometres per hour



Military personnel can control Strike remotely to scope out battlefields



The TITAN Strike and Sentry work together to track targets and engage the enemy

army's eyes in the sky, along with a delivery system for those on the ground. The KX-4 LE TITAN is a drone with a plug-and-play payload, thanks to a lift capacity of around six kilograms. Aerial mapping sensors, cameras and gimbals are some of the modular options that attach to it, allowing it to survey area, track targets and lock-on up to five kilometres away. Also offering back-up from the skies, the TITAN can drop resources such as life jackets and even deliver stun grenades for combat support. Having eyes in the sky can offer unique tactical support for soldiers on the ground, but if they're spotted, there are many ways to take them down, from frequency emitting drone guns to actual bullet-loaded bastistics. Stealth is key to staying airborne. Only 16.8 centimetres long, the Black Hornet PRS has been described as a form of nano surveillance for its ability to quietly zip ahead of the troop. Resembling a toy helicopter, this pocket-sized UAV is deceptively high-tech. It is equipped with advanced electro-optical and infrared cameras and sensors to offer the operators a clear view of the threats ahead.

"The TITAN can drop resources such as life jackets and even deliver stun grenades"



The Throwbot 2 can clear obstacles up to 5cm tall

Robotic infiltrator

Designed to withstand repeated drops of 9.1 metres on concrete, the Throwbot 2 is a compact remote-controlled robot able to scope out potential threats without the need for human intervention. Equipped with a colour camera, microphone and infrared illumination, this tiny scout can survey indoor locations and feed information back to a handheld monitor to provide a better picture of what is inside. To maintain its stealthy nature, Throwbot is around 21 centimetres in length and emits less than 59 dBa from a one-metre distance (about the same as a radio turned down to low volume).



The Black Hornet PRS is almost silent, making it perfect for use in combat

JACK OF ALL TRADES

THERE'S ONE MACHINE THAT CAN SEEMINGLY DO IT ALL - THE THEMIS IS ABLE TO CARRY OUT SEVERAL TASKS IN THE FIELD THANKS TO ITS MODULAR DESIGN

Scout

As robotic eyes on the ground, the THeMIS can be used as a simple patrol unit or observer.



Launch pad

In collaboration with the KX-4 LE TITAN drone, this landing pad allows controllers to select launch and landing sites in the field.

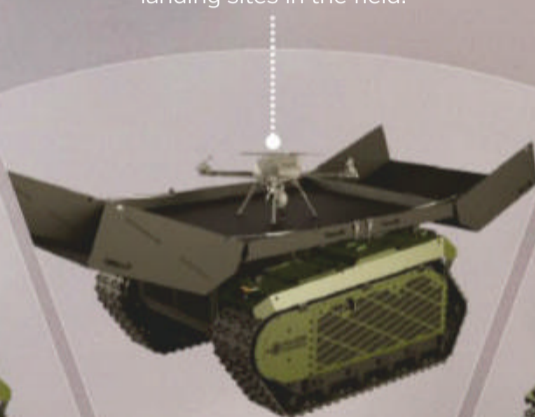

Detective

Equipped with the Pegasus Multiscope, this module can survey areas difficult to reach by foot, and with built-in sensors has the ability to monitor heat signatures and air particulates.



Bomb defuser

The THeMIS GroundEye is module system that can detect explosive IEDs buried beneath the ground.



Weapon

As a robotic soldier, this weaponised module can lock on to targets and fire remotely.

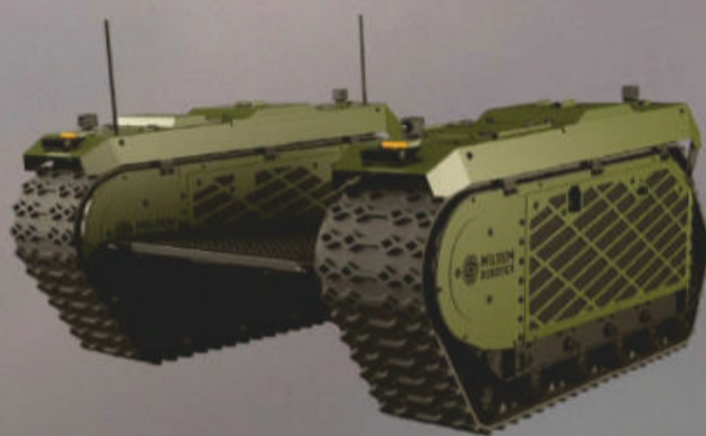

Fire fighter

Swapping a gun for a hose, it can be used to direct water to the higher levels of a burning building.

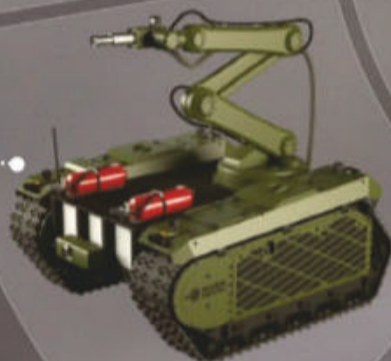

Tankbuster

To disable enemy tanks, this THeMIS can be equipped with anti-tank missiles.



Medic

Supplies aren't the only thing this robot can transport. As a medevac module, the THeMIS can be used to load a stretcher carrying a wounded soldier, driving them away to safety.



Carrier

Fundamentally the THeMIS is a supply vehicle, enabling resources to reach soldiers at base or in the field without risking more lives during battle.





What is an ion wind plane?

This futuristic concept could revolutionise aviation with silent and non-polluting power systems

Air travel is one of the greatest barriers to reducing carbon emissions. Fossil fuel-powered jets and propellers have been the kings of aviation ever since the Wright Brothers' first flight in 1903, but the ion wind plane, developed by physicists at the Massachusetts Institute of Technology, could be a game-changer. In late 2018, it became the first 'aircraft' weighing more than a few grams and with no moving parts to achieve sustained flight.

Known by its working name, 'Version Two', it's powered by electro aerodynamics, using powerful lithium-polymer batteries to generate a high voltage that ionises nitrogen in the atmosphere. This creates an ionic wind, where supercharged ions collide into neutral air molecules and charge their electrons to create a silent forward thrust.

Version Two only managed a 60-metre flight, but its completion is a huge step in the right direction to reduce the reliance on the internal combustion engine for air travel. If the size of ion wind planes can be increased while still maintaining enough thrust, this technology could be pivotal in the growth of electrical and hybrid aircraft power systems. Version Two weighs just over 2.45 kilograms, but the batteries need to produce 40,000 volts to generate an ionic wind powerful enough for it to take off.

The big question is, can an even higher voltage be generated or can the process be made more efficient so less voltage is required? If the answer is yes, then the image of purely electric-powered long-haul passenger aircraft, transporting commuters and holidaymakers across the globe, without the need to burn fossil fuels, is an exciting one.



Ionic wind technology could be used to power military drones behind enemy lines

Creating the ion wind

How high-voltage batteries 'energise' the air to create forward thrust

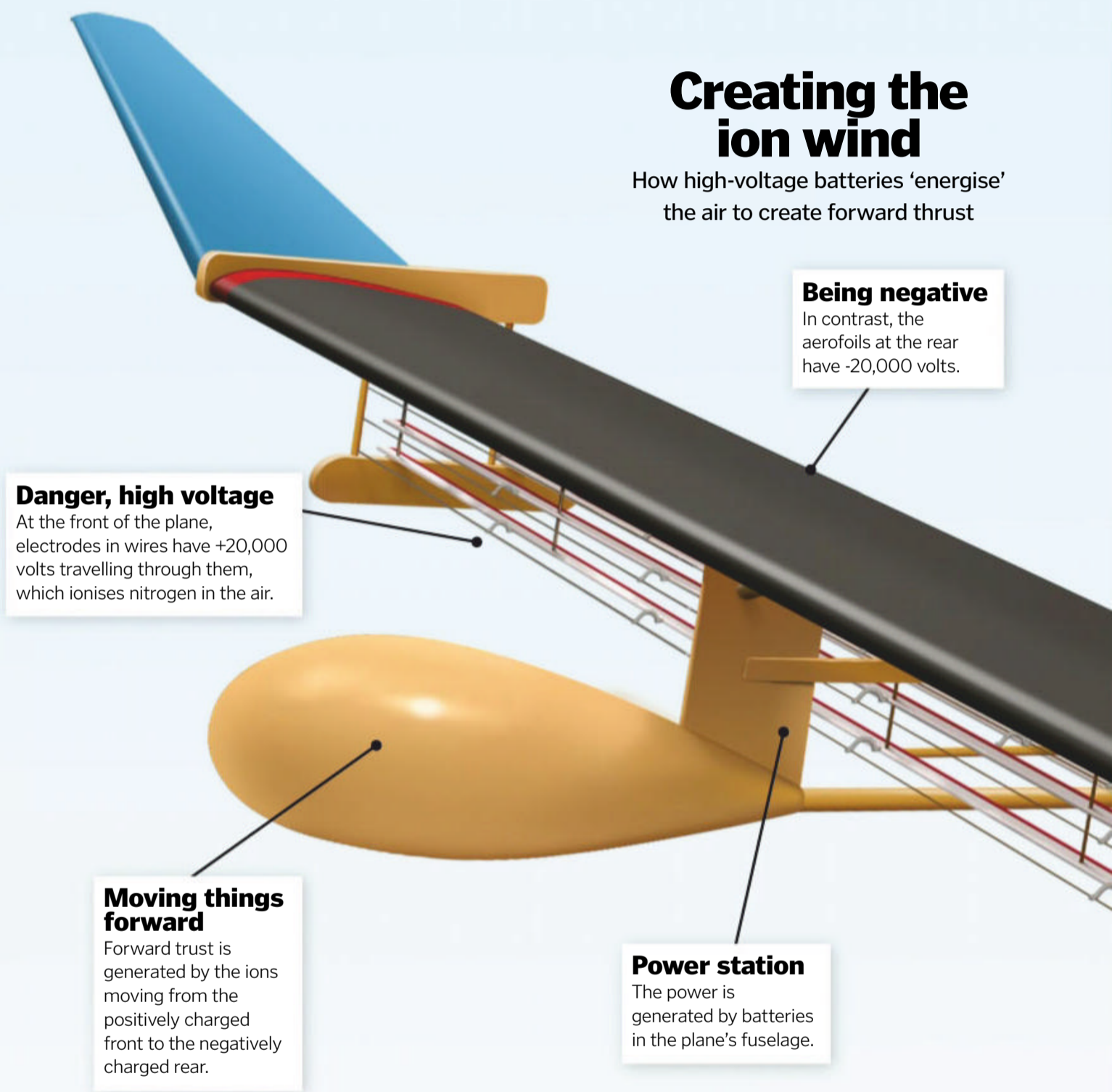

Danger, high voltage

At the front of the plane, electrodes in wires have +20,000 volts travelling through them, which ionises nitrogen in the air.

Being negative

In contrast, the aerofoils at the rear have -20,000 volts.

Moving things forward

Forward thrust is generated by the ions moving from the positively charged front to the negatively charged rear.

Power station

The power is generated by batteries in the plane's fuselage.

EasyJet's electric future

Within 20 years, flights from London to Paris, Amsterdam and Edinburgh could be completed by electric-powered planes. The brainchild of EasyJet and US-based company Wright Electric, new environmentally friendly aircraft could revolutionise the commercial aircraft industry and make a huge reduction in carbon emissions. Instead of a propeller or turbine, motors will be placed in each wing, which will be powered by lithium ion and aluminium air batteries in the fuselage. The lack of jets will also increase the plane's aerodynamics as, without turbines hanging below the aircraft, it will be more streamlined and half as noisy as EasyJet's conventional passenger planes.

EasyJet hopes to have an electric fleet up and running within 20 years, and a nine-seater prototype is hoped to take flight later in 2019. The electric aircraft are estimated to be ten per cent cheaper to operate, resulting in potentially cheaper tickets for passengers, so the development will be a win for the producer, consumer and the planet.



The finished version will hold 120 passengers and have a range of more than 500km

© MIT Electric Aircraft Initiative; Flybe; Illustration by The Art Agency/Jean-Michel

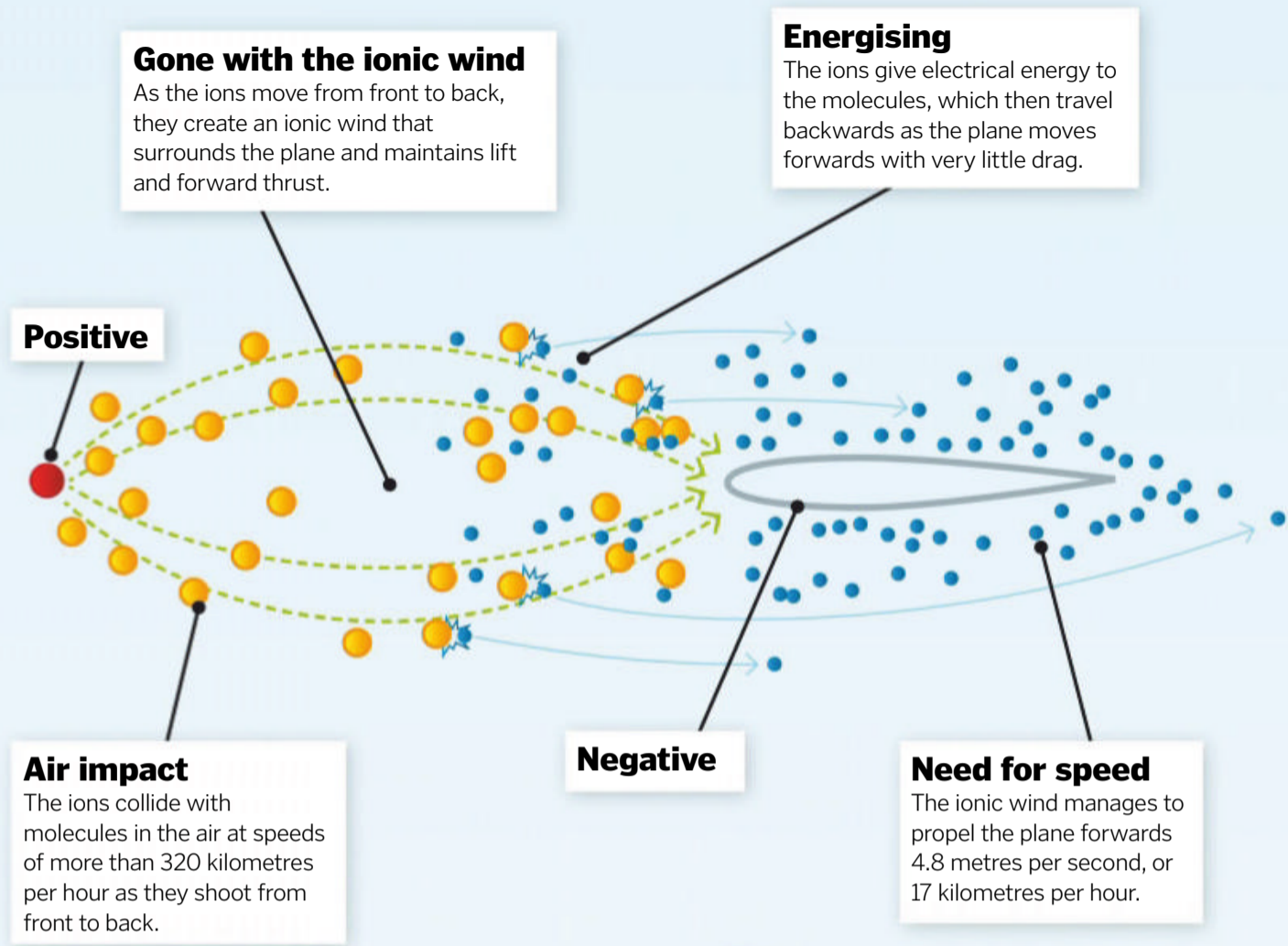

Round the world in solar power

In July 2016, the Solar Impulse 2 became the first renewable energy-powered aircraft to fly around the world. Starting and landing in Abu Dhabi, the solar-powered aircraft spent a combined total of 23 days in the air over its 17-month journey, and flying across four continents and two oceans. The 43,000-kilometre flight was made possible by 17,248 solar cells, no thicker than a human hair, which powered four lithium-ion batteries. Its efficiency was increased by wide wings that used air currents to glide and it was able to fly through the night as power was stored in the batteries during daylight hours.



The Solar Impulse 2 proved that long-distance flights could be achieved without fossil fuels

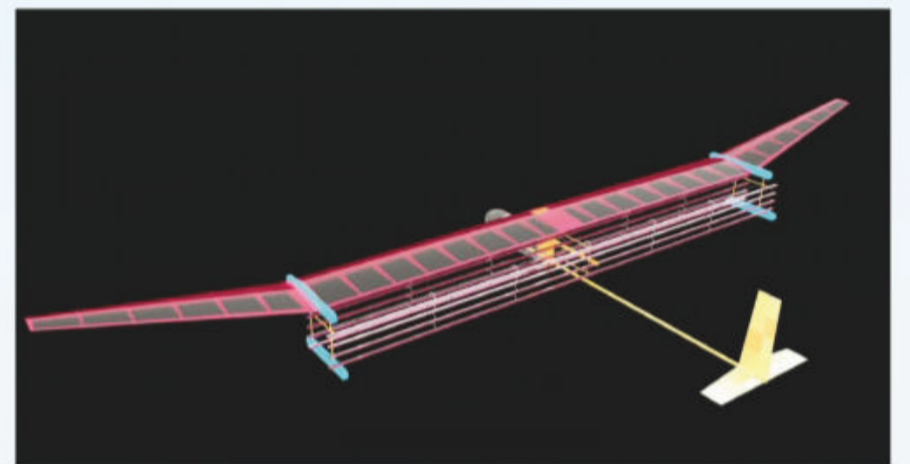

The ion wind plane was inspired by the spaceships in Star Trek that go boldly without a propeller or jet engine



The technology isn't ready to replace long-haul passenger liners just yet

"This technology could be pivotal in the growth of electrical and hybrid aircraft power systems"



Uplifting earth

How hydrovacs safely excavate the ground without damaging pipes

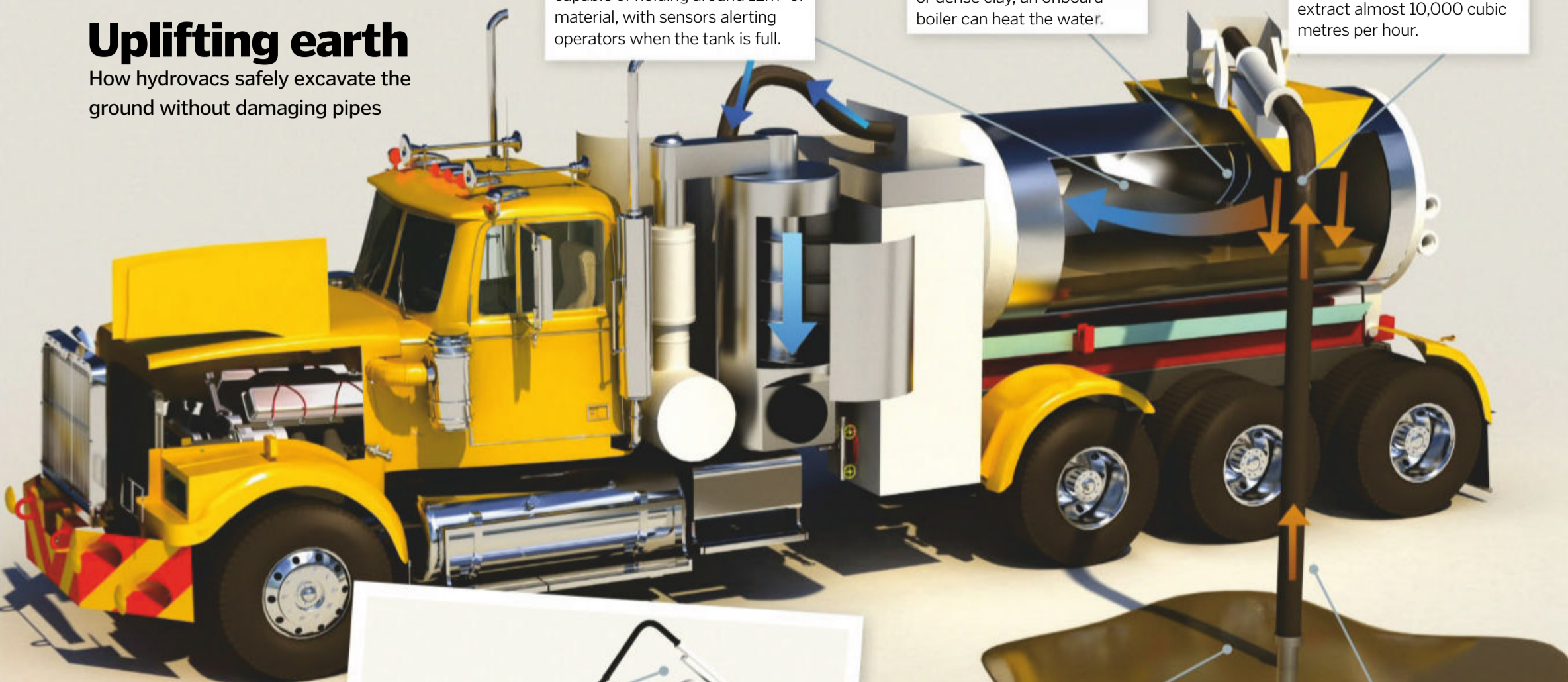

Storage

Sucked-up debris is dropped in the storage tank, typically capable of holding around 12m³ of material, with sensors alerting operators when the tank is full.

Heating

In order to break apart hard ground such as frozen earth or dense clay, an onboard boiler can heat the water.

Vacuum

Lifting rocky debris requires a lot of suction power. The internal vacuum pump can extract almost 10,000 cubic metres per hour.

Boom

A retractable telescopic boom is used to suck up the broken ground, moving it to be stored in the tank. The boom can reach around eight metres away from the vehicle.



Digging

As pressurised water breaks up the ground, the boom collects the broken debris. Hydrovacs can access several metres into the ground for extraction.

Water wand

Water is manually delivered to the target via a pressurised wand at speeds of around 80 litres per minute and 3,000 PSI.

Super-sucking excavator trucks

How do these hydro-vacuum vehicles suck up tons of rubble?

Long gone are the days of manual digging on construction sites with the introduction of these mammoth vacuum vehicles. Commonly known as hydrovac trucks, these purpose-built machines utilise hydro-vacuum excavation to break down the dense rock. There are two main components to achieve this: highly pressurised water is jetted onto the ground to break it apart and form a slurry. Simultaneously a vacuum boom sucks up the slurry and debris as it goes. The remains are stored in the truck's vast containment unit, until they're driven to a dumping site and removed from the bowels of the vehicle. Hydrovac trucks use different methods to expel the rocky remains, including a hydraulically lifted tank to tip out rubble and water, or a moving wall within the tank to push the ground out.

One of the biggest problems with digging underground is the potential for compromising

water mains, communication lines, gas pipes or electrical cables. The hard tools used in manual digging are a particular threat to this underground infrastructure. However, as hydrovacs only use pressurised water to excavate, the risk of breaking a pipe or severing a cable is significantly reduced.



Hydrovacs are used to access underground infrastructure, including cleaning US storm drains

To the rescue

Although hydrovacs are used for everyday maintenance missions, they can also offer a helping hand in times of crisis, in particular landslides. These occur for several reasons, often when earthquakes or heavy rainfall loosens the ground - and the results can be extremely devastating.

In early 2018 a landslide occurred in California, depositing hundreds of tons of debris onto a highway. Hydrovac trucks, along with many other maintenance vehicles, arrived at the scene and used their vacuuming abilities to remove the mud and rubble, redistributing it to another site.



Hydrovacs helped clean up the debris from a landslide in California in 2018

© Westech; Getty; Illustration by Alex Pang

Special offer for readers in **North America**



4 FREE issues

When you subscribe*

“The action-packed science and technology magazine that feeds minds”



Order hotline **+44 (0)344 848 2852**

Online at www.myfavouritemagazines.co.uk/hiwusa

***Terms and conditions** This is a US subscription offer. 4 free issues refers to the US newsstand price of \$9.99 for 13 issues being \$129.87, compared with \$87 for a subscription. You will receive 13 issues in a year. You can write to us or call us to cancel your subscription within 14 days of purchase. Payment is non-refundable after the 14-day cancellation period unless exceptional circumstances apply. Your statutory rights are not affected. Prices are correct at point of print and subject to change. Full details of the Direct Debit guarantee are available upon request. UK calls will cost the same as other standard fixed-line numbers (starting 01 or 02) included as part of any inclusive or free minutes allowances (if offered by your phone tariff). For full terms and conditions please visit: bit.ly/magtandc. Offer ends 31 May 2019.

OFFER
EXPIRES
31 May
2019



WHAT THE Victorians DID FOR US

Delve into the era of endless invention, innovation and discovery that shaped the modern world

Words by **Jodie Tyley** and **Tim Williamson**

Everything from selfies to sound systems, and iMacs to milkshakes owe their existence to the scientists and engineers of the 19th century. Motorcars, steam trains and even the humble bicycle enabled people to

travel across vast distances quickly and cheaply for the first time. Studies of microbiology enhanced our understanding of diseases, leading the way to cures and immunisation, while the telephone, radio and telegraph

revolutionised the way we communicate, connecting people across countries and continents. Here are just a few of the most important inventions and discoveries for which we can thank the geniuses of the Victorian age.

1817–1880s

Bicycles

Although there are designs for two- and four-wheeled human-powered vehicles dating back all the way to the 15th century, the first successful, safe and popular human-powered bikes did not begin to emerge until some 400 years later. In 1817 German aristocrat Karl von Drais designed the *Laufmaschine* ('running machine'), which was simply two wheels on a wooden frame and a seat. To propel the machine the rider would simply run on the ground, then raise their feet and let the wheels do the work.

By the 1860s a pedalled bicycle, called the *velocipede*, had been developed in France, which enabled riders to rotate the front wheel by foot. This was also known as the 'boneshaker' due to the uncomfortable ride caused by its solid wheels. By the 1880s the modern bike had taken shape, with the pedals moved to the centre of the frame, powering the rear wheel via a chain to enable greater control and stability.



The Rover safety bicycle was far safer and more stable than previous bikes and formed the blueprint for future designs

1865

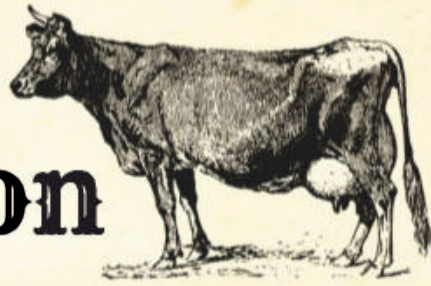

Pasteurisation

Before the mid-19th century food and drink had an incredibly short shelf life, and in particular milk deteriorated very quickly, becoming foul smelling, undrinkable and wasted. This changed with the development of pasteurisation, a process of heating liquid until almost boiling to destroy as many harmful microorganisms as possible before rapidly cooling it. Chemist Louis Pasteur made his discovery while researching the fermentation process of wine. He was attempting to discover the cause of sour or spoiled wine and found that the rapid heating and cooling prevented any germs or microbes causing contamination. His studies also created a greater understanding of the role of living microorganisms during fermentation. The Frenchman lent his name to his discovery, which today is a vital stage in the mass production of dairy and alcohol products. However, his research into microbiology, or germ theory, also led to a greater understanding of the causes of and cures for diseases.



Louis Pasteur was one of the 19th century's leading microbiologists

Thames Water Utilities sewer cleaning team inspects the Fleet River's Victorian-built sewer



An engraving showing the deadly pollution of the Thames

1866

London's sewer system

In the early 19th century the River Thames was a stinking cesspit of raw sewage. Disease was rife and more than 10,000 Londoners were killed by cholera between 1853 and 1854. One particularly hot summer brought the city to a standstill in what was called the 'Great Stink', finally prompting the government to take action. Chief engineer Joseph Bazalgette constructed an underground network of 'intercepting sewers' that collected the waste that flowed out to the Thames using gravity and the occasional huge steam pump. The sewers were dug by hand – mechanical diggers didn't exist – and constructed using 318 million bricks and new water-resistant Portland cement. However, the sewage still wasn't 'treated' until the 1880s!

1829

Stephenson's rocket

Among the first major steps on track to steam-powered passenger trains came in 1829 when engineers George and Robert Stephenson's 'Rocket' reached a top speed of 48 kilometres per hour – a lightning pace for the era. Although it wasn't the very first steam locomotive, Rocket combined several efficient design features and was selected to service on one of the world's first passenger railway lines, the Liverpool and Manchester Railway.

Cylinders

Two angled cylinders were positioned on each side of Rocket. Each contained a piston and were connected to the wheels via cranks.

Boiler

Rocket's boiler was heated by multiple copper tubes, which ran from the firebox. These enabled heat to be transferred very efficiently.

Blast pipe

Steam from the boiler moved up through a blastpipe and into the cylinder, where the pressure would build.

Piston

The change in pressure created by the build-up of steam drove the piston back and forth, which in turn drove Rocket's wheels.

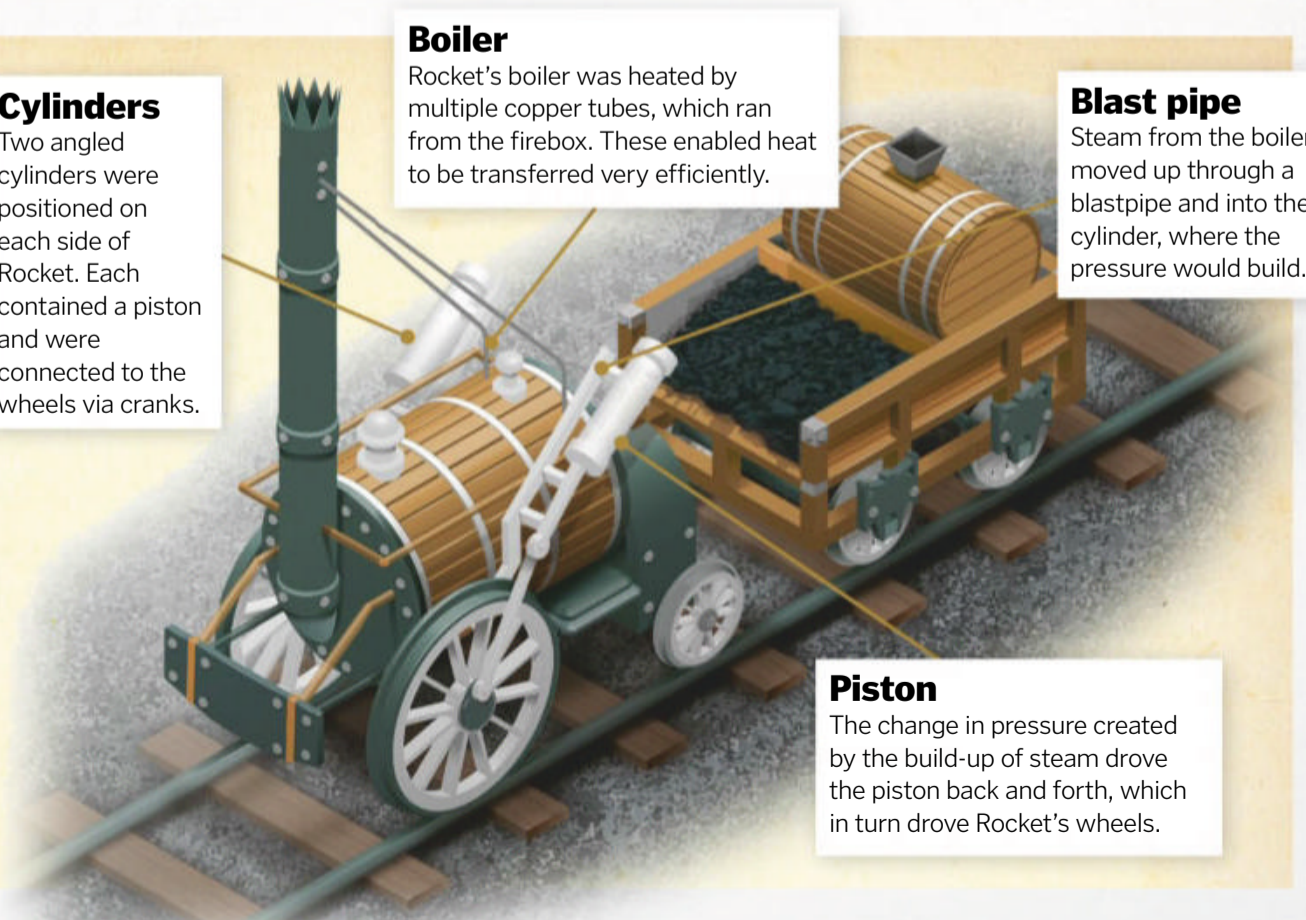



The first-ever X-ray was of Anna Bertha Röntgen's hand

1895

X-rays

One of the 19th century's most important discoveries happened entirely by accident. German physicist Wilhelm Conrad Röntgen was experimenting with passing electrical currents through gas-filled tubes, similar to fluorescent light bulbs, when he noticed a screen start to glow. It was illuminated by invisible rays coming from a tube that was covered in black paper, meaning they had the power to penetrate solid objects! Röntgen created the first X-ray image by swapping the screen for a photographic plate. The image revealed the bones in his wife's hand. The rays passed through tissue easier than bone, and the 'shadows' this creates form an image. X-rays are a type of high-frequency electromagnetic radiation similar to light but, unlike light, their higher energy means they can pass through most objects.

1877

Phonograph

A cross between the telephone and telegraph, this unusual contraption could both record sound and play it back. Its inventor, Thomas Edison, envisioned it being used for dictating letters, for recording lessons in school or recording phone conversations, to name a few applications. The first words he recorded were "Mary had a little lamb" and he was amazed when the machine played his words back.



Thomas Edison seated next to his invention in 1878

Reproducer sound box

The recording on the tinfoil vibrated the needle (stylus), which in turn vibrated the diaphragm, reproducing the original sound.

Reproducer stylus

A stylus on the other side would be placed into the groove and the cylinder was put in its original position.

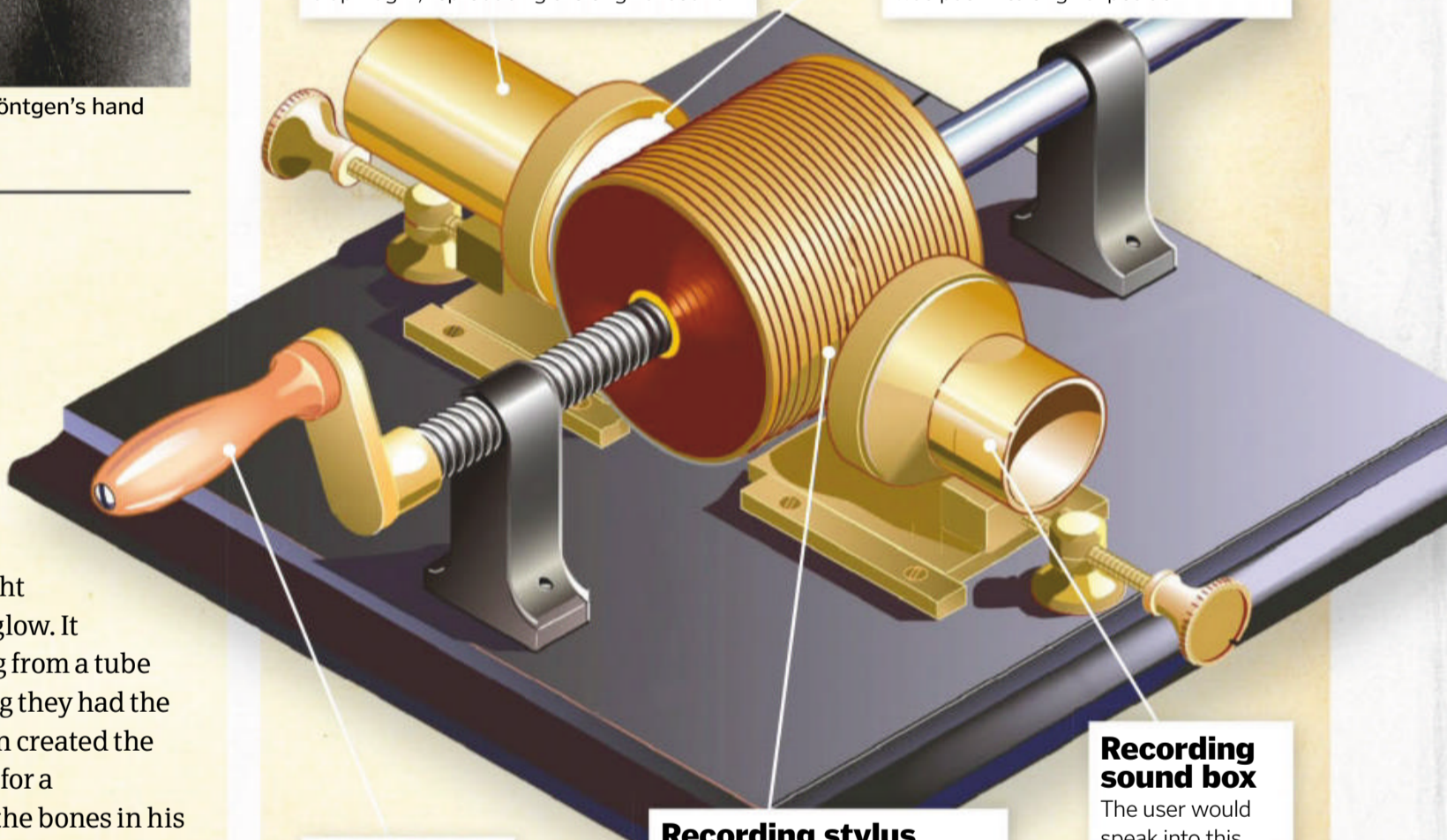

Hand crank

This turned the cylinder that was wrapped in tinfoil.

Recording stylus

A needle called a stylus moved with the vibrations from the diaphragm, making indentations on the tinfoil cylinder in vertical grooves.

Recording sound box

The user would speak into this, directing sound waves into the diaphragm - a thin membrane that vibrated.

An age of progress

Light-sensitive photographic paper

William Henry Fox Talbot

By using light-sensitive silver nitrate, Talbot created 'photogenic drawings'

Christmas card

Sir Henry Cole

Henry Cole was too busy to write to his friends over the holiday season, so commissioned the first Christmas card



Sewing machine

Elias Howe

This was not the first sewing machine, but Howe's refined design has much more in common with our modern machines

First glider to be flown by a pilot

George Cayley

A replica on display at the Yorkshire Air Museum

1839



1840

Adhesive postage stamp

Sir Rowland Hill

The Penny Black features a profile image of Queen Victoria

1843

1844

Morse Code

Samuel Morse

1845

Rubber tyres

Robert Thomson

1846



1848

Modern water turbine

James Francis

1849

Concrete

Joseph Monier

1849

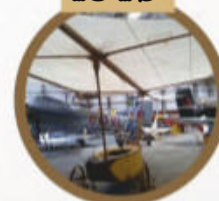

1851

Public flushing toilets

George Jennings

The evolution of photography

A snapshot of cameras through time



1876

Telephone

The first words ever spoken on the telephone were: "Mr Watson, come here; I want to see you." It was inventor Alexander Graham Bell talking to his assistant on 10 March 1876. The telephone he created looked very different to its modern counterparts, but operated using a mouthpiece, transmitter and a receiver.



An actor portrays Alexander Graham Bell speaking into an early model of the telephone

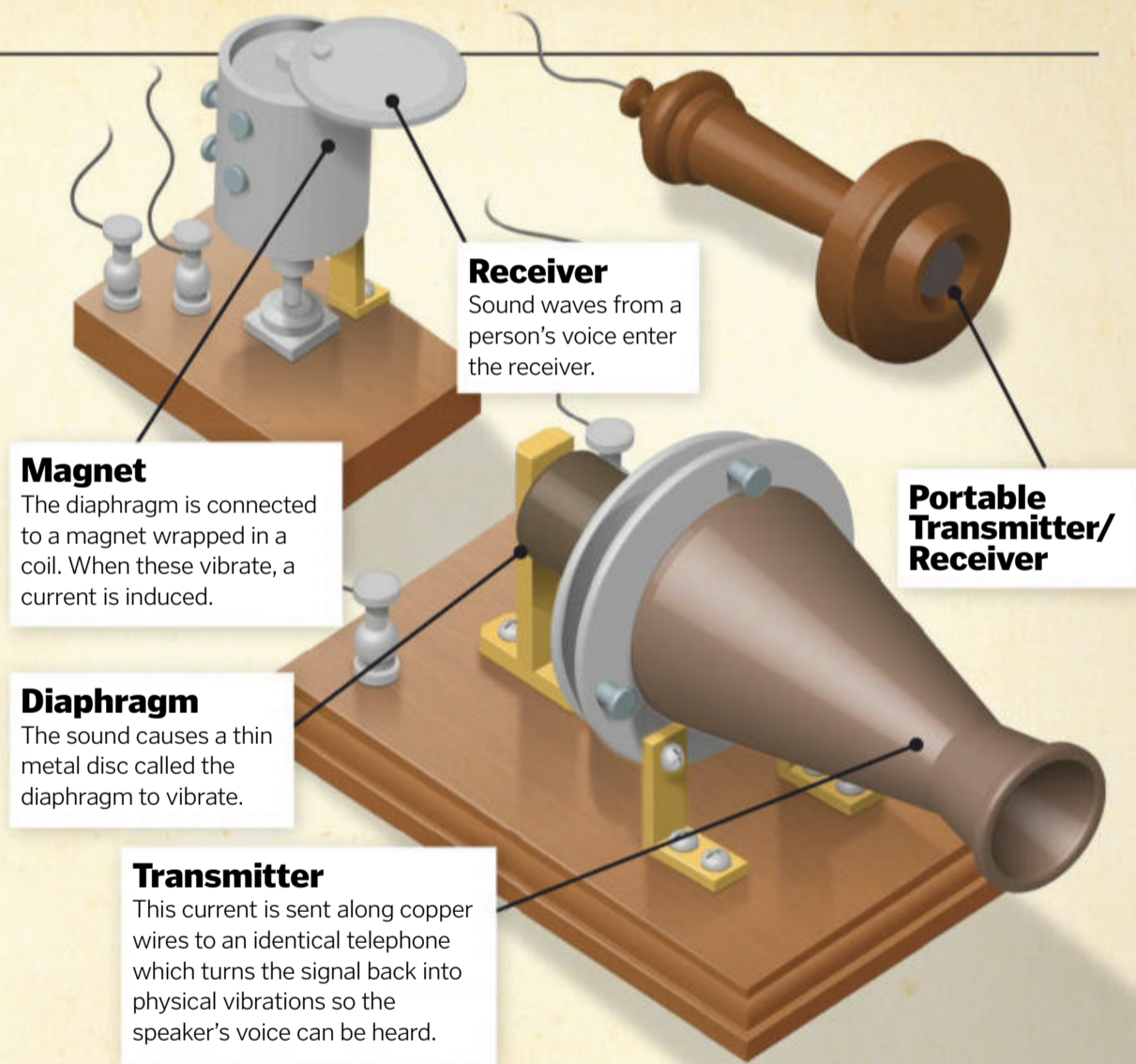

Post box

Richard Redgrave
The unusual octagonal design was made by John M Butt & Co of Gloucester, England



1853

Underground railway

London's Metropolitan Railway opened between Paddington and Farringdon Street.



1854

Turning iron into steel
Henry Bessemer

1863



Typewriter

Christopher Sholes
The first commercially successful typewriter included the QWERTY keyboard

1873

Denim jeans
Jacob Davis and Levi Strauss

1873



Electric light bulb

Thomas Edison
He wasn't the first to develop the light bulb, but Edison improved the design so it lasted longer

1879

Three-wheeled motor car 'motorwagen'

Karl Benz

1885

Gramophone

Emile Berliner
Berliner was the first person to record on flat discs that could be mass-produced



1887

Wireless communication

Guglielmo Marconi

1895

Cinematograph

Lumière brothers
This motion picture film camera also doubled as a projector

1895

How Brexit happened

From membership to separation, here are the key moments that have led to the UK's divorce from the European Union



The UK, Denmark, Ireland, and Norway signed the Treaty of Accession in 1972

1967-1973

The UK submits two more applications to join the EEC, which are rejected. However, in 1973 the country is granted entry into the EEC along with Denmark and Ireland.

1961

The UK submits an application to join the EEC, however the application is rejected in 1963.

1957

The European Economic Community (EEC), also known as the Common Market, is formed. The EEC is made up of Belgium, France, Italy, Luxembourg, the Netherlands and West Germany, under the Treaty of Rome.

1960

The European Free Trade Association is created as a rival to the EEC. It's comprised of Austria, Denmark, Norway, Portugal, Sweden, Switzerland and the UK.

1975

After just two years of membership the UK holds a referendum to decide whether or not to stay in the EEC. The vote resulted in a decision to remain, with 67.2 per cent for and 32.8 per cent against.

1992

Under the new Maastricht Treaty, signed by UK Prime Minister John Major, the European Union (EU) is formed to offer a single currency and the coordination of social and security policy, in which EEC members are enrolled.

1995

NEW MEMBERS
Austria, Finland and Sweden join the EU.

2017

Under Article 50 of the Lisbon Treaty, UK Prime Minister Theresa May gives formal notice of the UK's intention to leave the EU.

1981

NEW MEMBER
Greece joins the EEC.

1984

Prime Minister Margaret Thatcher organises a rebate on the UK's contribution to the EEC.

1985

The UK refuses to sign The Schengen Treaty to join in a borderless zone across member states.

1986

NEW MEMBERS
Portugal and Spain join the EEC.

1997

Security and employment policies are strengthened by the signing of The Treaty of Amsterdam by member states.

2016

Britain carries out a nationwide referendum to decide its membership of the EU. The result is 51.9 per cent to leave, 48.1 to remain.

2013

NEW MEMBER
Croatia joins the EU.

2007

NEW MEMBERS
Bulgaria and Romania join the EU. The Treaty of Lisbon is signed by UK Prime Minister Gordon Brown to extend the powers of the European parliament.

2004

NEW MEMBERS
Cyprus, Czech Republic, Estonia, Hungary, Latvia, Lithuania, Malta, Poland, Slovakia and Slovenia join the EU.

2001

The Treaty of Nice is signed by the 15 member states of the EU to prepare for the next large intake of members to strengthen the institution.

Nov-Dec 2018

The UK government finally reaches a Brexit deal with the EU, however the deal is rejected by a UK parliament vote.

Jan 2019

After renegotiations between the UK government and the EU, an amended deal is presented and again rejected in a vote by the UK parliament.

29 March 2019

The proposed date for the UK to leave the EU.



17,410,742 (26.5% of the UK) voted to leave the EU



16,141,241 (24.5% of the UK) voted to remain

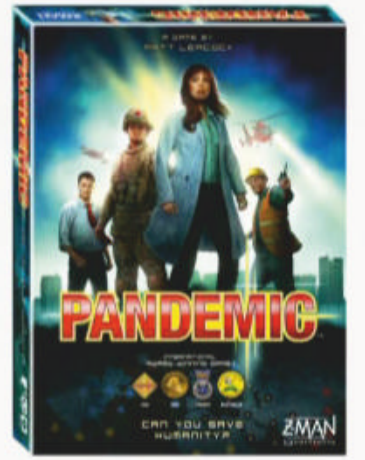

Pandemic

Four deadly diseases are breaking out across the world – can you stop them?

■ Publisher: Asmodee/Z-Man Games ■ Price: £36.99 / \$49 ■ Number of players: 2-4 ■ Recommended age: 8+ ■ Typical game time: 45 minutes

Most board games pitch the players against each other in cutthroat competition (we're looking at you, *Monopoly*), so it's nice to be able to compare notes and discuss strategy with the people around the table. Like the way you'd have to if you really were a small team of globetrotting scientists and researchers in a race against time to cure four lethal pathogens that are spreading around the planet. Your goal is to find a cure or eradicate the four diseases - black, red, yellow and blue - before they hit a deadly threshold.

In setting the board up, you use the Infection deck to determine which of the cities will begin to be infected, indicated by the coloured cubes. Each player then picks a character role with a unique skill at random, plus four cards off the top of the player deck. In turn, players perform up to four actions, which can include moving along the connecting lines to an adjacent city or using one of the city cards drawn from the player deck to fly to another city.

Building research labs using your player cards is vital, as this is the only way in which you can

cure diseases. Using an action to eliminate units of disease from cities is also a high priority, because any increase on three infections on the same city space results in an outbreak, moving the human race a step closer to annihilation.

Pandemic usually begins with some delegation of duties and often ends with players fire-fighting pop-up plagues around the globe. But however the game finishes – which is usually with the players losing at the hardest setting – the ever-increasing intensity makes it a thrilling play every time.

Epidemic cards

These advance the infection rate further down the track. Four of these are shuffled into the player deck for the standard game – five or six for the harder settings.

Outbreak track

The outbreak marker moves down the track with every new outbreak. Cure the diseases before it reaches the skull and crossbones!

Role play

Each player picks a role with a specific skill: the Medic, for example, can use an action to remove all cubes of one colour from a city, instead of just one cube.

Biohazard Warning

Easy to learn, the difficult bit is co-ordinating your team to beat *Pandemic's* hardest setting

Infected cities

When a city with three units of infection is further infected, an outbreak occurs, infecting adjacent cities and moving the outbreak marker further down the track.

Infection rate

At the end of each turn, players draw cards according to the Infection rate marker to determine how many new infections occur.

Player deck

Players draw two cards from this deck as a part of their turn. They're usually city cards, but sometimes they'll be a dreaded epidemic card.

Discovered cures

Place the vial over the appropriate disease to indicate it has been cured. Flip the vial if you eradicate the disease after curing it.



BRAIN DUMP



Because enquiring minds need to know...

MEET THE EXPERTS

Who's answering your questions this month?



JODIE TYLEY



TOM LEAN



LAURA MEARS



JAMES HORTON



JO STASS

Why is it called the 'Doppler effect of blueshift'?

Aurora Smith-Rowe

Blueshift enables astronomers to understand the movement of distant objects, because as a source of light, like a star, moves towards an observer, its wavelength shortens. As the wavelength shortens, its colour shifts away from the red end of the visible light spectrum towards the violet end. The reason it's called 'blueshift' rather than 'violetshift' is because humans cannot see violet light well, but we can see blue better, which is next to violet on the spectrum. **TL**

As a light source gets closer, its wavelength shifts towards the blue end of the spectrum

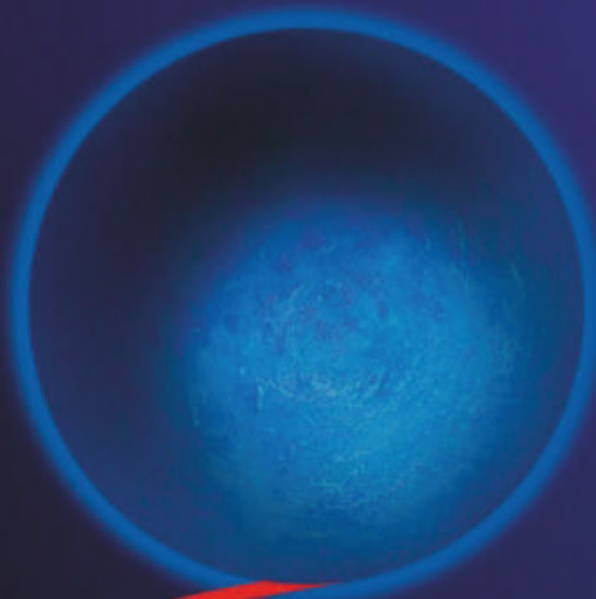

MOVEMENT AWAY FROM OBSERVER

MOVEMENT TOWARDS OBSERVER

Want answers?

Send your questions to:

f How It Works magazine

t @HowItWorksmag

@howitworks@futurenet.com

Can animals be allergic to humans?

Alan Harvey

■ Humans don't usually trigger allergies because we bathe often and shed little skin and hair. However, our perfumes, soaps and laundry detergents can trigger allergic reactions in our pets, with cats being the most vulnerable. **JH**

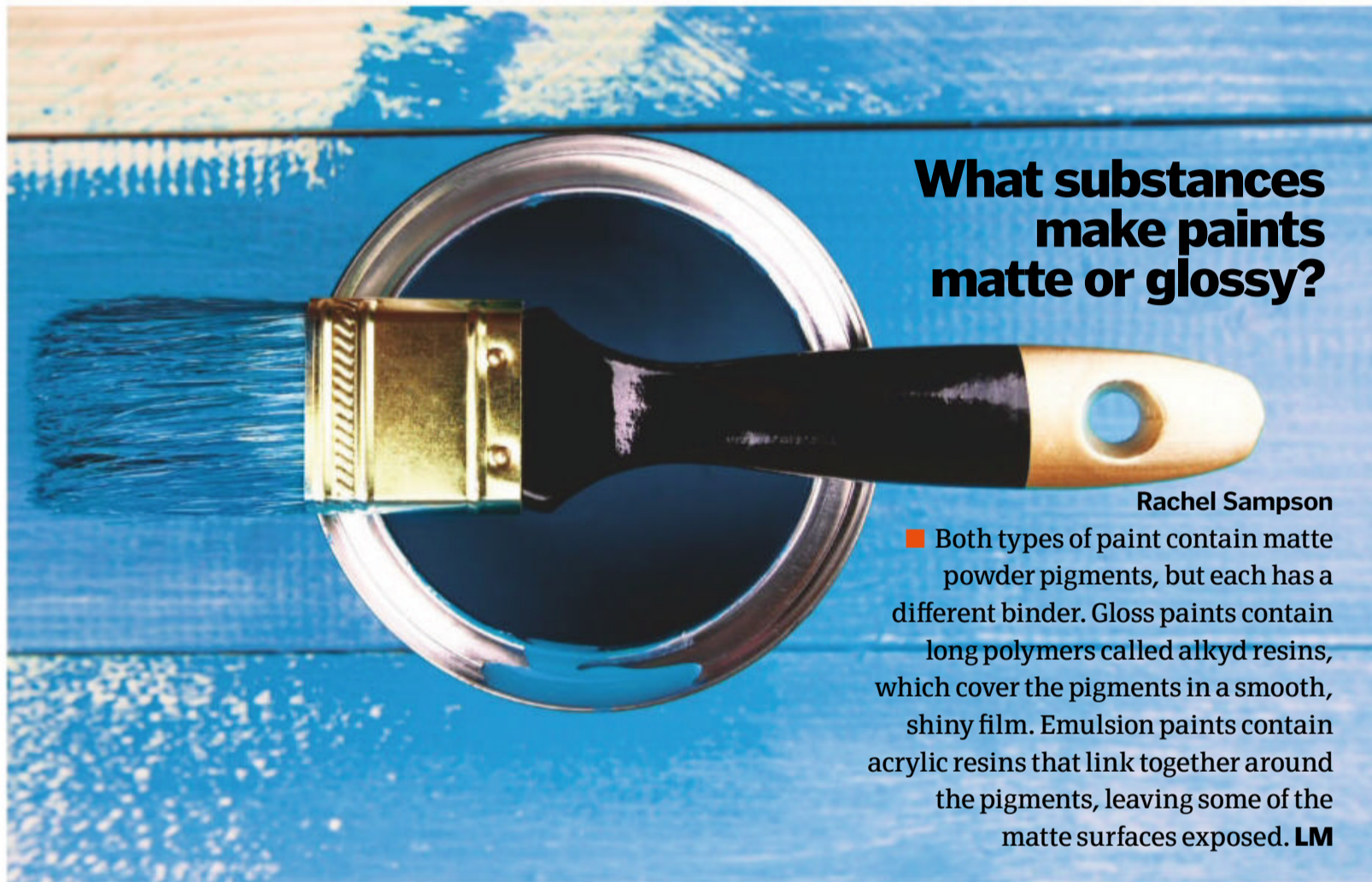

What substances make paints matte or glossy?

Rachel Sampson

■ Both types of paint contain matte powder pigments, but each has a different binder. Gloss paints contain long polymers called alkyd resins, which cover the pigments in a smooth, shiny film. Emulsion paints contain acrylic resins that link together around the pigments, leaving some of the matte surfaces exposed. **LM**

What was the deadliest battle in WWI?

Albert Ryder

■ The first half of the 'Great War' was a battle of attrition, where generals would repeatedly send their men slowly forward in a mostly futile attempt to gain ground. This led to huge losses of life on all sides, and more than 1 million soldiers died in five different offensives. The deadliest single battle likely belongs to the Battle of the Somme, however, which claimed over 57,000 British casualties of which 19,240 men lost their lives on its first day. **JH**

The Battle of the Somme began on 1 July 1916 and lasted 141 days



© Getty



NEW MANUALS FROM HAYNES



Broadleaf and conifer models (all variations covered)
A comprehensive guide to selecting, planting and maintaining trees.
Robert Rogers and Tony Kirkham

RRP £22.99



From 13.8 billion years ago to the infinite future
An insight into the study of the universe and our place in it.
David M. Hordard

RRP £22.99



2500 BC onwards
An insight into the construction, meaning and exploration of the Great Pyramid of Giza.

RRP £22.99

AVAILABLE AT
HAYNES.COM
AND ALL GOOD BOOKSHOPS







The gas giants of the Solar System contain a surprising amount of liquid

If solid and gas planets exist, could liquid planets exist too?

Ulysses Lee

Mercury, Venus, Earth and Mars are rocky planets, while Jupiter, Saturn, Neptune and Uranus are all 'gas giants', but these categories are a bit deceptive. Take Jupiter, for example. It's the biggest planet in the Solar System, made mostly from hydrogen gas. But it isn't at all airy. Its gravitational pull is enormous, which creates immense pressure beneath its swirling surface. In Jupiter's core the pressure is up to 100 million times higher than on Earth. The intense conditions inside gas giants press their atoms so close together they become liquid, or even metal, below the surface. **LM**

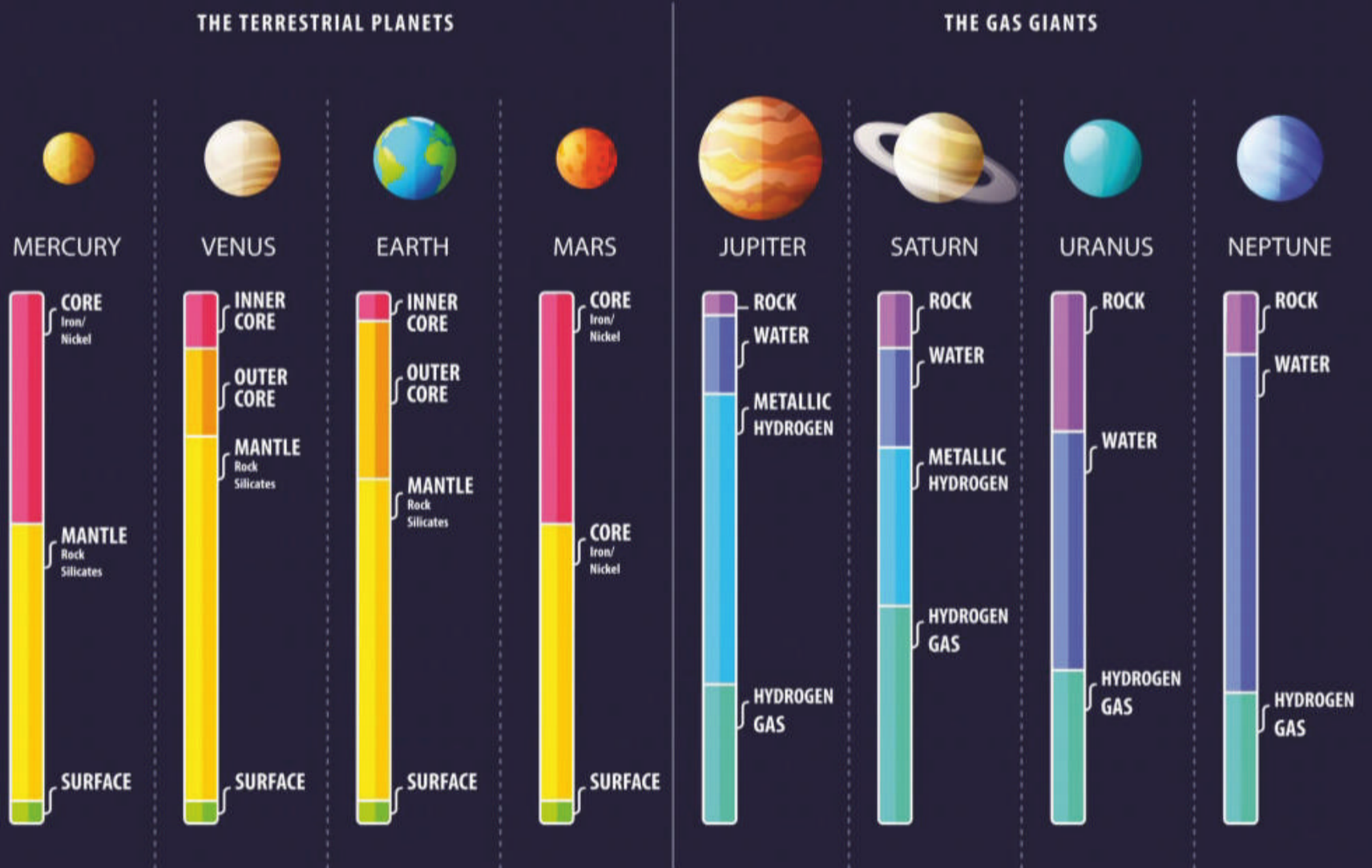

Studies show that soap is unlikely to make you ill



Can germs survive on soap?

Lucy Matthews

Bacteria can live on soap, but studies have shown they are unlikely to transfer during handwashing. Bars of soap were contaminated with E. coli and other disease-causing bacteria, and participants washed their hands as normal. When scientists found no detectable levels of bacteria on the participants' skin, they concluded that "little hazard exists in routine handwashing" and encouraged the use of soap and water to prevent the spreading of disease. **JT**

Quantum computers are generally large machines and are at an experimental stage still

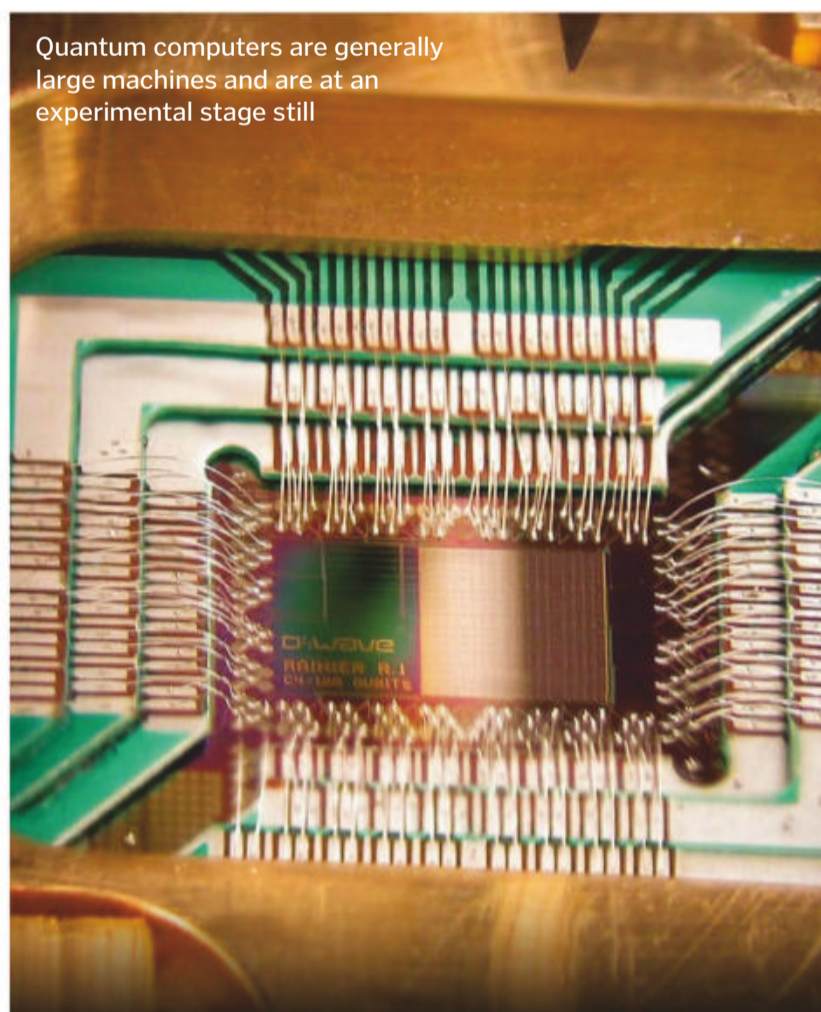

Will quantum computing ever be possible for personal devices?

James Smeed

Quantum computers, based on quantum mechanics and subatomic particles, could offer incredible advances in processing power but are still at an experimental stage. It's thought that they'll be better-suited for specialist tasks like artificial intelligence research, rather than general computing, making it unlikely to be used in a personal device. They also need to be kept extremely cold, so they are large and require a lot of energy, making them impractical as personal devices – at least in the near future. **TL**



Why is green tea good for you?

Gagan Nahar

■ Green tea is rich in antioxidants, which are known to slow down or prevent cell damage, helping to protect the body against disease. Green tea has more antioxidants than black tea due to its lack of processing, but claims that it can reduce the risk of cancer or help with weight loss are unsupported. **JS**



How does Google's AI 'dream'?

Katherine Clark

■ Google, like many companies developing AI, are fond of using artificial neural networks. These involve using an algorithm based on the human brain, where a layer of artificial 'neurons' receive a signal and, if it's strong enough, pass the signal on to the next layer. This tool can be incredibly effective at recognising patterns, but the tricky bit is learning what's going on in those middle neuronal layers – what pattern is the algorithm learning? To try and answer this, the Google team took an algorithm that had been taught to identify objects in images and allowed it to 'dream'. They gave it an input of random noise and asked it to use its knowledge to create an image, just as we do when we sleep. The results were some striking abstract pictures. **JH**

The 'dreaming' AI converts pictures of random noise into beautiful abstract images

A fever is a side effect of your body's attempt to fight an infection

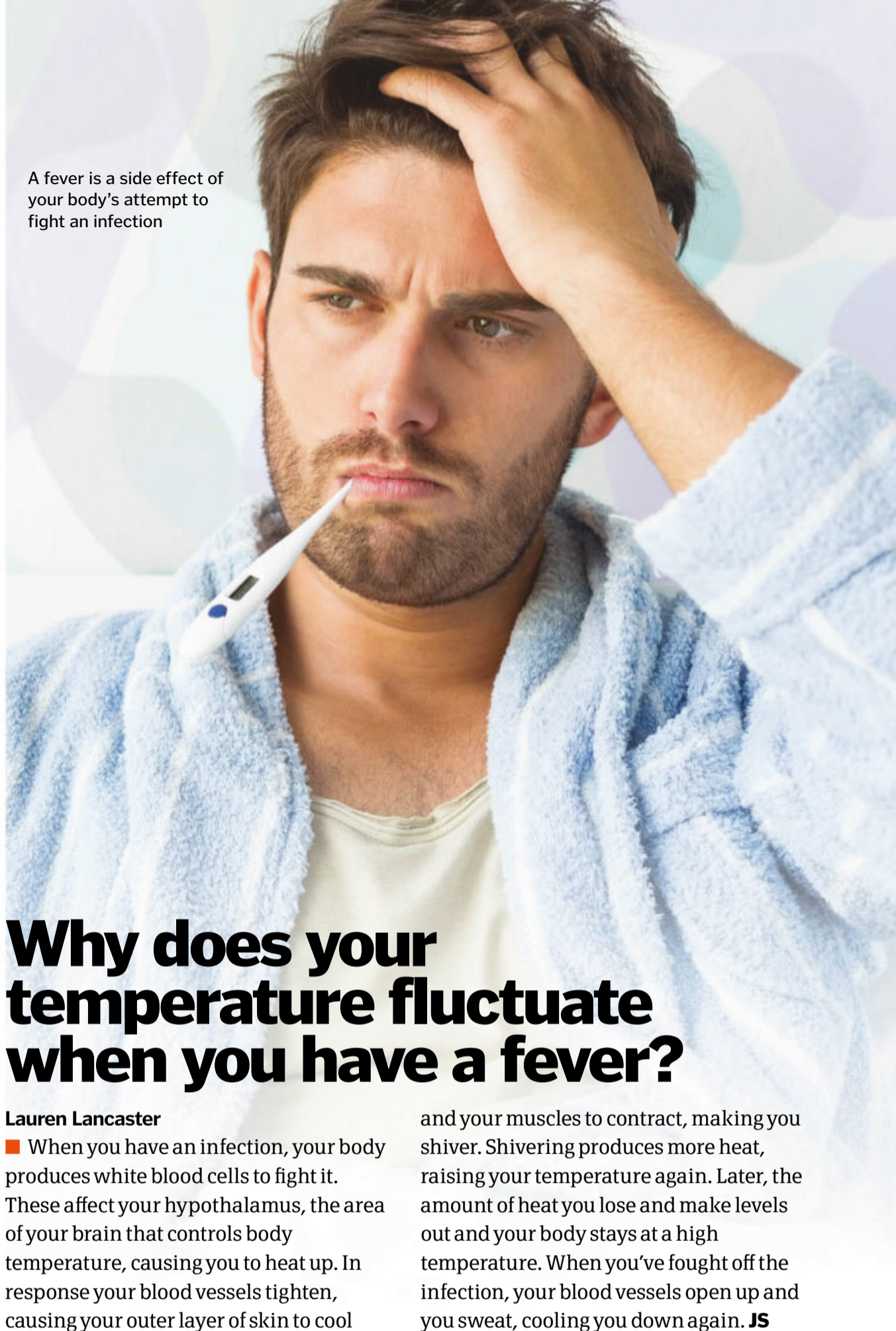

Why does your temperature fluctuate when you have a fever?

Lauren Lancaster

■ When you have an infection, your body produces white blood cells to fight it. These affect your hypothalamus, the area of your brain that controls body temperature, causing you to heat up. In response your blood vessels tighten, causing your outer layer of skin to cool

and your muscles to contract, making you shiver. Shivering produces more heat, raising your temperature again. Later, the amount of heat you lose and make levels out and your body stays at a high temperature. When you've fought off the infection, your blood vessels open up and you sweat, cooling you down again. **JS**

What is the definition of a species?

Sebastian Lewis

■ A species is a group of living things that can breed to produce 'viable' offspring. This means the babies will survive and be able to have babies of their own. Some different (but biologically similar) species can interbreed, such as a horse and a zebra, but the offspring cannot reproduce. **JT**



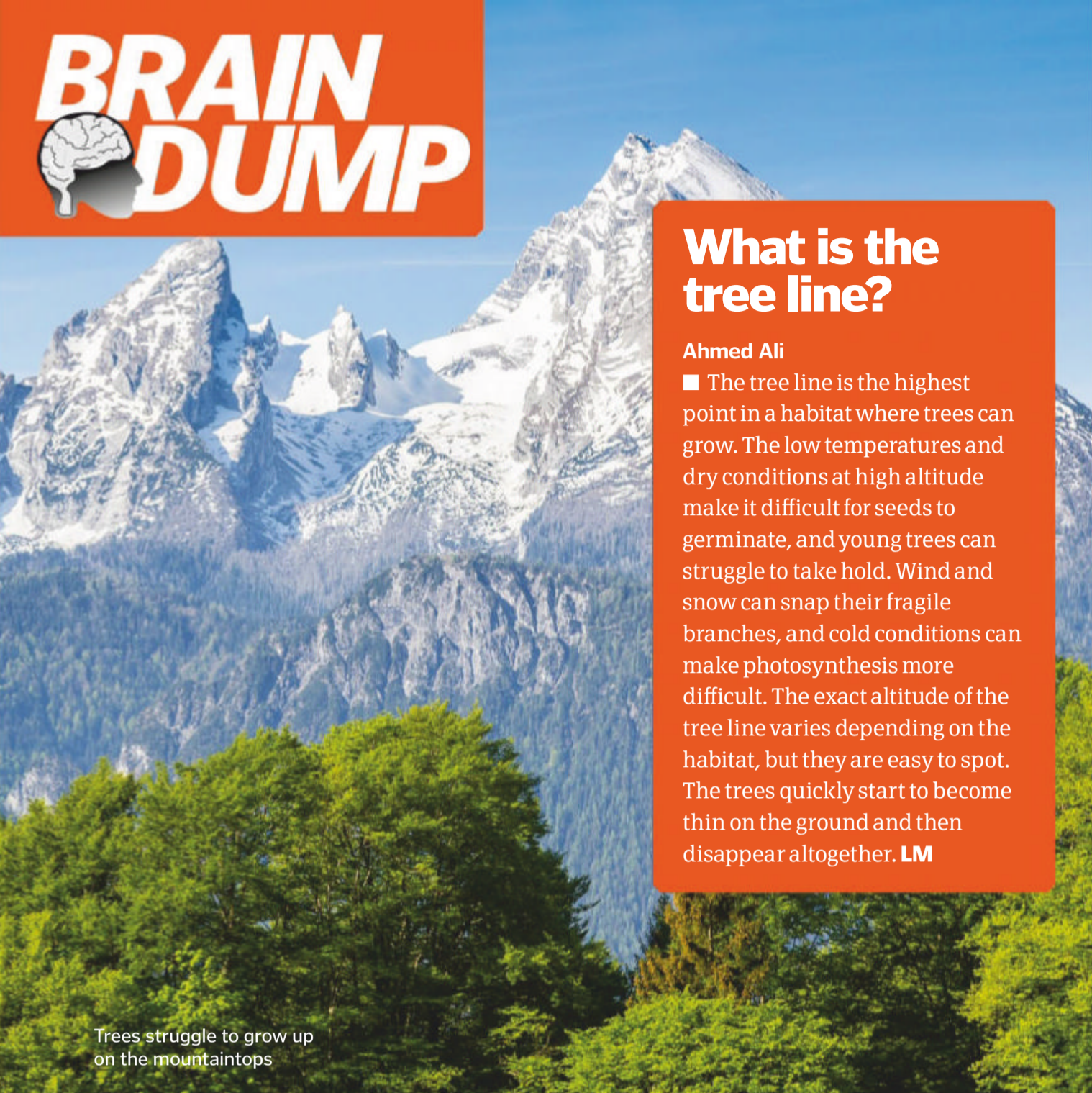

Trees struggle to grow up on the mountaintops

What is the tree line?

Ahmed Ali

■ The tree line is the highest point in a habitat where trees can grow. The low temperatures and dry conditions at high altitude make it difficult for seeds to germinate, and young trees can struggle to take hold. Wind and snow can snap their fragile branches, and cold conditions can make photosynthesis more difficult. The exact altitude of the tree line varies depending on the habitat, but they are easy to spot. The trees quickly start to become thin on the ground and then disappear altogether. **LM**



Is the bottom of a fridge colder than the top?

Jane Fondant

■ In most fridges, the bottom shelf is the coldest part because cold air sinks. However, if your fridge has an ice-making compartment, then the space nearest that will be the coldest. **JS**



Who created the periodic table?

Titus Birch

■ The table we recognise today was created by Russian chemist Dmitri Mendeleev in 1869. It included the 63 known elements at the time, and he left space for those yet to be discovered. Today there are 118 confirmed elements. **JT**

How are dams built? How is the river diverted during construction?

Oliver Johnson

■ To prepare a site for a new dam, a tunnel is built through one side of the valley to lead the river around the construction site. A smaller dam, called a cofferdam, is then built upstream to divert the river through this tunnel. Another cofferdam may also be built downstream to prevent the water flowing back up into the construction area. Next the site is cleared and a foundation plinth is laid, before the dam is constructed from concrete and steel. **JS**



Before building a dam, the river has to be diverted to keep the construction site dry



Why do we get sweaty palms when nervous?

Matt Bain

■ Sweating is mainly to cool the body down, but it can be triggered by stress. When we get nervous, the body is triggered into 'fight or flight' mode and activates sweat glands to cool the body, and to give your hands more grip by making dry palms moist. **TL**

Want answers?

Send your questions to:

f How It Works magazine

@HowItWorksmag

@howitworks@futurenet.com

Do all the planets in the Solar System ever align?

Owen Jones

■ The planets can never all come into perfect alignment as their orbits have different tilts, but they get close every few thousand years, when they roughly line up in the same sector. The last time this happened was over 1,000 years ago, and it won't happen again until 2492. **TL**



Prohibition protesters call for the repeal of the 18th Amendment



What was the role of oracles in ancient Greece?

Heidi McBrian

■ Oracles were seen by the ancient Greeks as the conduit to the gods. Only they could directly communicate with them on your behalf – but for a fee. Some oracles became extremely powerful and influential figures, such as the oracle at Delphi, who hosted kings and delivered prophecies that affected future wars. **JH**



What is a 'mirrorless' camera?

James Murphy

■ DSLR cameras use a 'reflex mirror' to reflect light from the lens up into a viewfinder. Mirrorless cameras let the light go straight to the digital sensors and show you a preview on a screen instead. **LM**

Why did the Prohibition start?

Chris James

■ Prohibition was a nationwide ban on the manufacture, sale and transportation of alcohol in the US from 1920-1933. It was the result of immense pressure from both religious and teetotaler groups who believed liquor was the scourge of society, causing violence and corruption. Others blamed booze for industrial accidents and low productivity, while some associated it with their hatred of immigrant communities. Many states had imposed their own bans, but by the time the US entered WWI in 1917, the cork was pretty much in the bottle. Grain conservation and cries to boycott German beer prompted the government to take action. **JT**

©Amy Getty

BOOK REVIEWS

The latest releases for curious minds

Distracted

Now do try to pay attention...

- Author: **Maggie Jackson**
- Publisher: **Prometheus Books**
- Price: **£14.99 / \$18**
- Release date: **Out now**

Technology is eating away at our lives. It's drawing out attention away from the real world, distracting us in social situations, and it's leading us to avoid direct contact and instead speak to each other through screens. We see it every day. And this, according to Maggie Jackson, is the first step towards a "dark age" of human history, and it is only by learning to avoid these technological distractions that we can avoid this awful fate.

This updated edition of *Distracted*, which was originally published ten years ago, adds a foreword that reflects on how the world has changed since 2009. Smartphones now connect us more than ever, tablets are everywhere (the iPad didn't even exist when this book was first published) and the internet has only gotten more consuming. Outside of this foreword, however, *Distracted* offers little extra context in the modern world, and as a result of this it feels slightly dated.

It's a shame, because the topic at the centre of this book – distraction and how to avoid it – is more relevant today than ever. Jackson raises interesting questions, discussing at length how multitasking isn't a positive term at all. In fact, while many people used to proudly claim they could multitask, the action now leads to distraction, with each task only getting a fraction of the person's attention. In 2019, when we're surrounded by more distractions than ever, the point truly hits home.

However, while Jackson quotes countless philosophers and social scientists in exploring the

themes, the book does little to further the conversations we've been having for the last decade. As technology has evolved, so has our understanding of it, as well as its effects. Modern journalism regularly covers these distractions, with new insights into screen time, the benefits and downsides of various technologies and so on. As a result, this book feels like it's missing something. It is interesting background reading for those looking into the social and psychological impacts of new technology, but we're not sure the new edition was really justified. In the end, while it's readable, we were left wanting a little more modern insight.

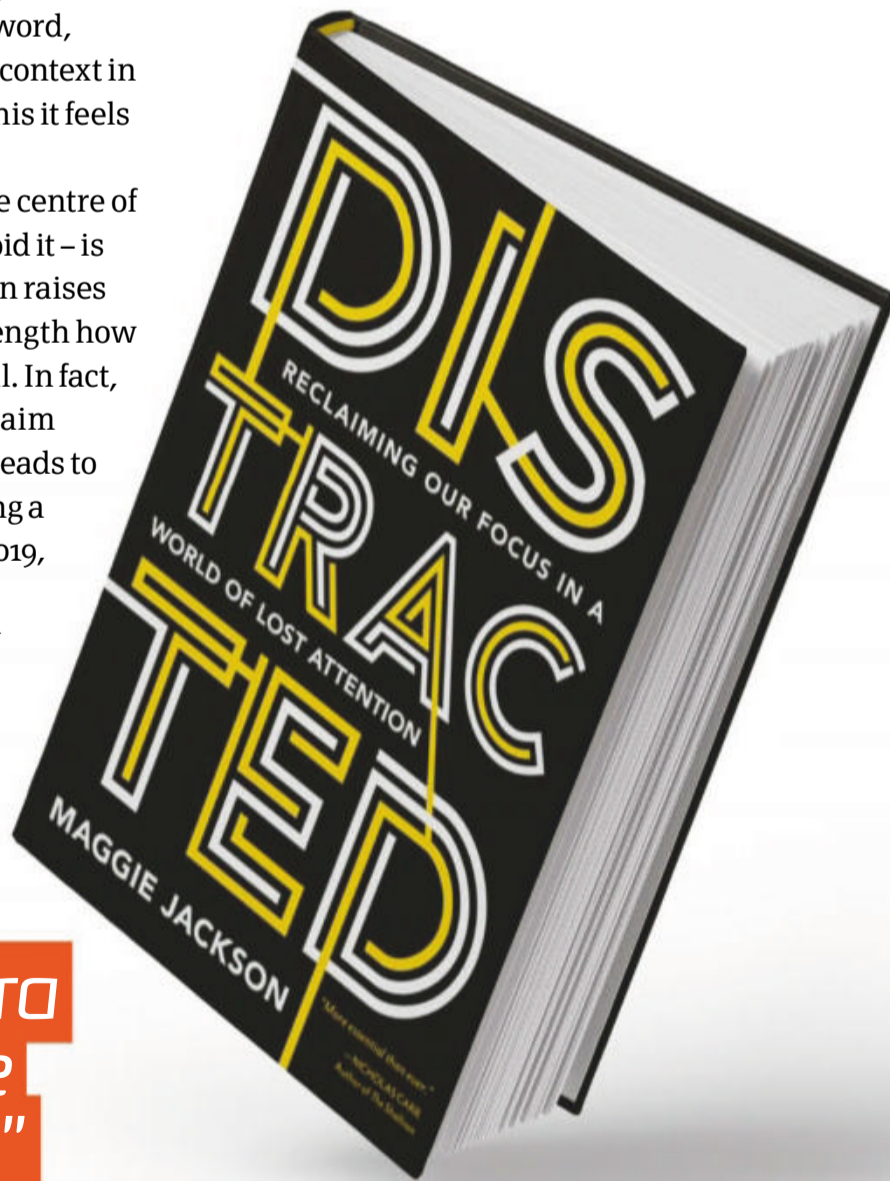

"Distracted offers little extra context in the modern world"



Anti-Science And The Assault On Democracy

War on errorism

- Author: **Michael J. Thompson, Gregory R. Smulewicz-Zucker (editors)**
- Publisher: **Prometheus Books**
- Price: **£19.99 / \$26**
- Release date: **Out now**

Without over-egging things, it's undeniable that we live in challenging times. Despite information being more readily available than ever, fact has increasingly come under threat – those who genuinely know best are ignored in favour of crowd-pleasing populism. On one hand it's democracy in action; on the other it's people abusing the system.

Looking to redress the balance, this collection of essays posits the major issues facing science today, and if there's anything we can do about it.

There's a grab bag of topics that'll undoubtedly suit the majority of people in one way or another – our favourites were Lee Smolin's *The Philosophy Of The Open Future* and Barbara Forrest's *Betraying The Founders' Legacy: Democracy As A Weapon Against Science* – so it's probably fair to say that it's quite an all-encompassing read. Perhaps it's more one to devote a weekend to rather than when you're tired in the evenings, but you can't doubt its importance as a topic.



The Prehistoric Times

Old-old school journalism

- Author: **Stella Gurney**
- Publisher: **Frances Lincoln**
- Price: **£5.99 / \$8.99**
- Release date: **Out now**

Endorsed by none other than the Natural History Museum, the reasons for *The Prehistoric Times*' popularity are immediately apparent. With its faux-retro design and wholeheartedly committed approach to giving children an easy and engaging access point into this area of history, it bears all the hallmarks of the aforementioned centre of wonder.

Taking the form of a compendium of quizzes, articles and diagrams, hidden away within are lessons subtly aimed at its youthful target audience, with the accounts from the dinosaurs themselves providing a humorous and often



poignant reading experience. Some of the lessons contained within are relevant to not just the time period of the subject matter but for more modern eras too.

At £5.99 it's a lot to ask (especially since it only comes in at 32 pages), but we'd recommend getting at least one issue of this just for the experience. Who knows, it might even mark the beginning of a lifelong obsession.



YT-1300 Millennium Falcon: Owners' Workshop Manual

Read it, Chewie!

- Author: **Ryder Windham**
- Publisher: **Haynes**
- Price: **£16.99 / \$29.99**
- Release date: **Out now**

Not content with producing immaculate-quality guides to real-life things, Haynes has started to delve into the realm of fiction too. There are few universes more fleshed out than that of *Star Wars*, and there isn't a spaceship anywhere near as iconic as the Millennium Falcon, so Haynes' next port of call represents a decent choice in a number of regards.

Charting the history of what Luke Skywalker memorably described as "a piece of junk", we discover more than we could possibly need to know about the early incarnations of the modified transport freighter, before professional gambler Lando Calrissian got his hands on it and

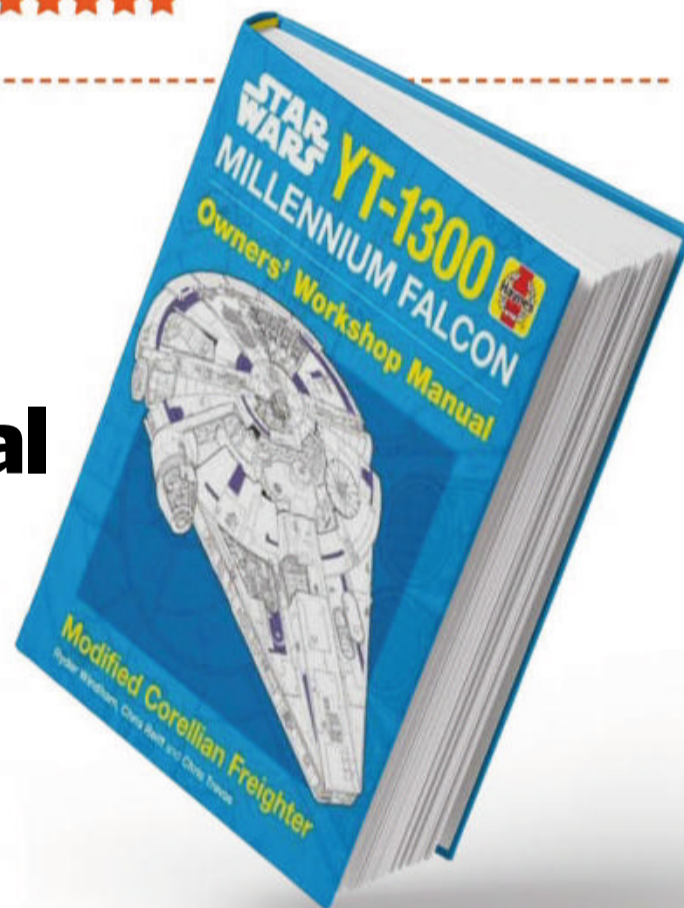

transformed it into the Kessel Run-acing superstar. From there, we get a full owner history and a comprehensive bit-by-bit breakdown of the Falcon's inner circuitry.

This isn't the best Haynes product, mainly due to uncharacteristic grammatical errors – Rey is referred to as "Reya" at one point – but otherwise this represents another solid entry in the publisher's canon.



Science Is Magic

Watch in wonder

- Author: **Steve Mould**
- Publisher: **DK**
- Price: **£12.99 / \$16.99**
- Release date: **Out now**

Science is a wondrous thing, but it's not always easy to get this message across, especially when teaching in schools is bogged down with minutiae like chemical formulas and the components of a living cell. What draws us in are the flashy experiments science inspires, which is where the impeccably named Steve Mould comes in.

Contained within these pages is an assortment of kid-friendly tricks guaranteed to make you rub your eyes in wonder. Magnetic fingers? Check. The old 'hovering tinsel' trick? Check. The chopstick challenge? You'll likely not know what this is without reading this book, but surely that's even more of a reason to pick this up, right?

Coupled with detailed instances of real-life wonder (such as the secret behind David Copperfield's incredible 1983 Statue of Liberty vanishing act), and you've got something the budding Einstein or Curie in the family will get plenty of enjoyment out of.

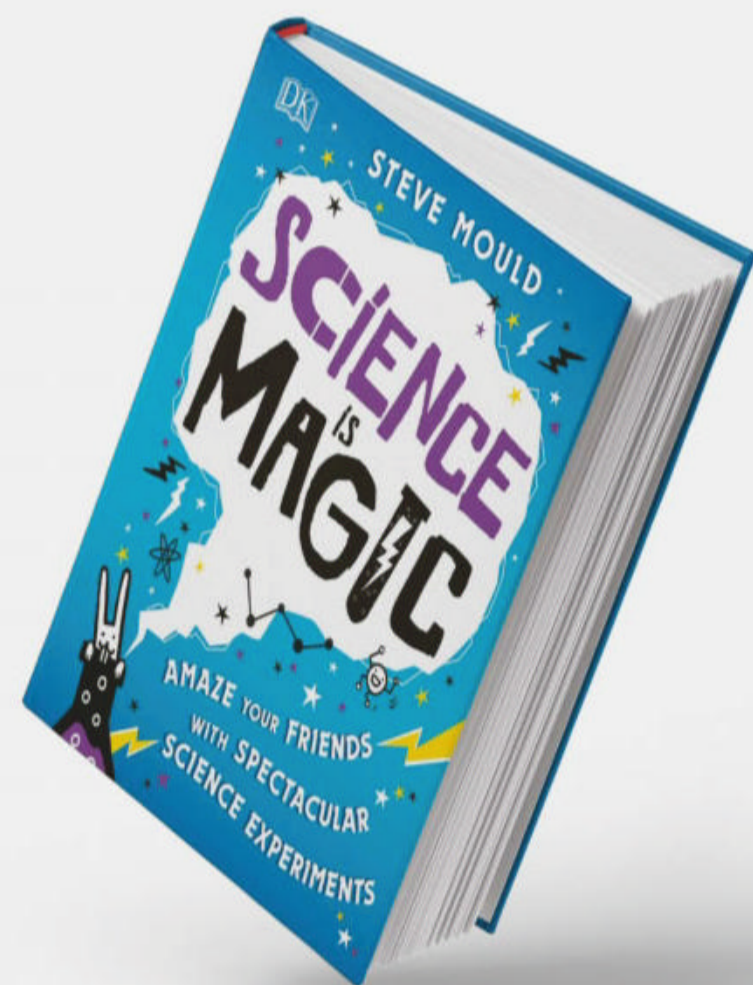

BRAIN GYM

GIVE YOUR BRAIN A PUZZLE WORKOUT

Quickfire questions

Wordsearch

M	E	T	H	A	N	E	G	S	M	U	L	C	E	R
O	D	H	S	L	C	L	O	B	J	T	A	A	H	J
Z	R	A	S	U	E	J	R	Y	R	L	N	V	S	I
T	O	L	O	E	X	E	I	L	N	A	T	F	T	N
B	S	Y	A	P	X	K	M	I	O	K	I	J	Y	D
E	O	P	U	I	S	U	Q	D	S	T	V	L	K	X
L	P	N	T	B	M	H	P	A	N	K	E	G	L	F
F	H	I	O	N	R	Y	F	R	E	S	N	O	S	E
U	I	F	N	M	O	D	V	Q	H	T	O	J	V	R
S	L	Q	O	D	T	R	S	Z	P	N	M	X	L	M
I	A	U	M	B	S	O	S	R	E	R	I	L	P	I
O	F	A	O	R	P	G	N	B	T	M	E	V	L	L
N	G	U	U	P	B	E	I	H	S	B	L	Y	Q	A
X	A	I	S	W	J	N	L	T	M	R	A	W	S	B
P	T	I	G	E	R	E	F	W	N	F	M	D	B	S

FIND THE FOLLOWING WORDS...

- ANTIVENOM
- AUTONOMOUS
- BELL
- BRAILLE
- BREXIT
- DROSOPHILA
- FERMILAB
- FUSION
- HYDROGEN
- ION
- LIDAR
- METHANE
- STEPHENSON
- STORMS
- SWARM
- TIGER
- ULCER

Q1 How hot is the Sun's surface?

- 304.85 Celsius
- 5504.85 Celsius
- 57,514.85 Celsius
- 577,614.85 Celsius

Q2 What is the world's fastest snake?

- Inland taipan
- King cobra
- Black mamba
- Tiger snake

Q3 In what year was Stephenson's 'Rocket' built?

- 1729
- 1789
- 1829
- 1889

Q4 What liquid rains on Titan?

- Methane
- Water
- Sulphuric acid
- Nitrogen

Spot the difference

See if you can find all six changes we've made to the image on the right



Sudoku

Complete the grid so that each row, column and 3x3 box contains the numbers 1 to 9

EASY

			5	7	6			
	6	8	1	4	3	5		
5	4		9			1		7
	2	7			5		1	8
	9	4	2	6	1		3	
1		5	7	9		4		6
9	7	1	6	2	4			3
	5	6		1			4	9
4	8	2	3	5		6	7	

DIFFICULT

8			7				9	
		4						7
	2			6	4			5
	8			3	9			
	6	7		2			1	
5							8	4
			8		5			
				9		2		
	7					6		3

What is it?

Hint: This common salad item usually comes in red, green or yellow varieties.

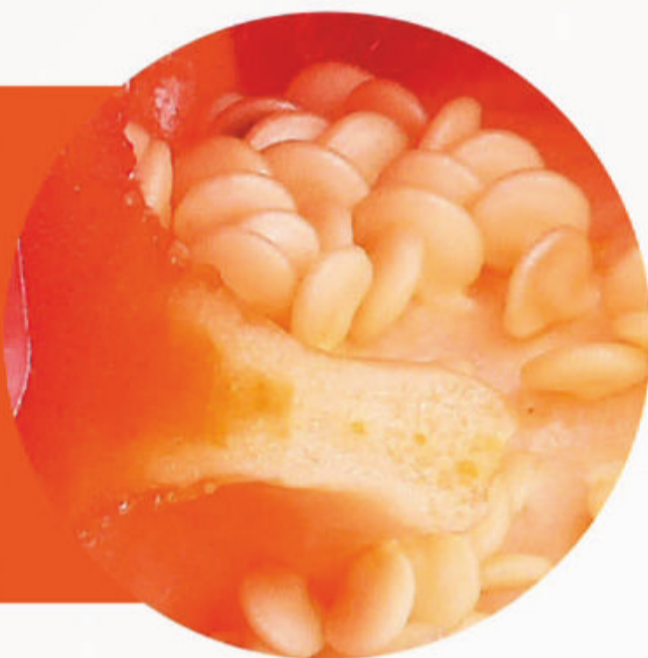

A

For more brain teasers and to test your problem-solving abilities, enjoy our *Mensa Puzzle Book*, which is packed with challenging problems and puzzles designed by experts.

Available from myfavouritemagazines.co.uk



ON SALE NOW!

Spot the difference



Check your answers

Find the solutions to last issue's puzzle pages

Quickfire questions

- Q1** Eurasia
- Q2** 2 billion
- Q3** 1840
- Q4** Dolly

What was it?



Pencil

HOW TO...

Practical projects to try at home



Make glowing potato goo

Create glow-in-the-dark oobleck using nothing more than potatoes and tonic water



1 Cut your potatoes

You need to break some potatoes down into small pieces. You can do this by grating a whole potato, slicing it with a knife into small pieces, or putting it in a dicer or blender.



2 Soak the bits

Next, put all of your potato pieces into a large mixing bowl and carefully pour hot water on top until the potatoes are completely covered. Stir the mixture around for a few minutes.



3 Sift out the solids

Put a sieve over another large bowl and pour the potatoes in to separate them from the liquid. Discard the potatoes and leave the liquid to settle for around ten minutes, until you see a separation.



4 Clean it up

We need to keep the white starch layer at the bottom of the bowl. Quickly pour out the liquid, and the starch should remain in the bottom. It might be dirty, so pour in fresh water and mix it.



5 Separate and dry

Pour your mixture into a jar and shake it. Leave it for ten minutes and you should see it separate again, with the dirty water at the top. Pour that away, then leave the starch until it's dry.



6 Add the tonic water

Take a spoonful or two of your white starch powder and put it in a small bowl. Add a spoonful of tonic water and slowly mix the two together. You're aiming to get a consistency like honey.



7 Don't stop mixing

If it's too dry, add a little more tonic water. It might be difficult to stir at times, but keep going until there's no powder left in the bowl. Now you've made a non-Newtonian fluid!

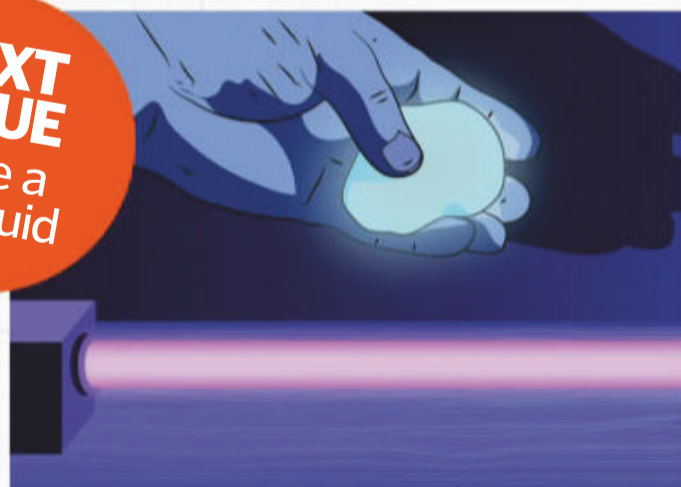

8 Experiment

Try picking some of the fluid up and moving it quickly around your hands like a ball. It acts like a solid, right? Now try turning off the lights and switching on a black light. You have glowing goo!

SUMMARY...

Oobleck is a non-Newtonian fluid; that is, a fluid that sometimes acts like a solid. By adding a liquid to your starch you make it flow, but when you exert a force on the liquid the tiny particles rub together. This friction increases the tension, so it briefly acts as a solid. It all glows in the dark because of quinine, a chemical in the tonic water, which reacts with the UV light from the black light.

Had a go? Let us know! If you've tried out any of our experiments – or conducted some of your own – let us know! Share your photos or videos with us on social media.

Disclaimer: Neither Future Publishing nor its employees can accept any liability for any adverse effects experienced during the course of carrying out these projects or at any time after. Always take care when handling potentially hazardous equipment or when working with electronics and follow the manufacturer's instructions.

WIN

A PAIR OF DIGITSOLES



Follow
Digitsole at:

 @Digitsole

 @Digitsole

 digitsole_

This month we're giving away a pair of Digitsoles to three lucky winners! Track and analyse your cycling activity with these smart insoles.

For your chance to win, answer the following question:

What is the temperature at the core of the Sun?

- a) **15 million degrees Celsius**
- b) **50 million degrees Celsius**
- c) **2 billion degrees Celsius**

**WORTH
£130!**



Send your entries by email to howitworks@futurenet.com with the subject 'Competition 123' or write to us at: **How It Works, Future Publishing, 33 Richmond Hill, Bournemouth, Dorset, BH2 6EZ**

Terms and Conditions: Competition closes at 00:00 GMT on 18th April 2019. By taking part in this competition you agree to be bound by these terms and conditions and the Competition Rules: www.futurenetcs.com. Entries must be received by email or post by 00:00GMT on 18/04/2019. Open to all UK residents aged 18 years or over. The winner will be drawn at random from all valid entries received, and shall be notified by email or telephone. The prize is non-transferable and non-refundable. There is no cash alternative.

Get in touch

If you have any questions or comments for us, send them to:

f How It Works magazine @HowItWorksmag @ howitworks@futurenet.com



Astronaut Scott Kelly spent 365 days on the International Space Station to study the effects of space on the human body

Letter of the Month

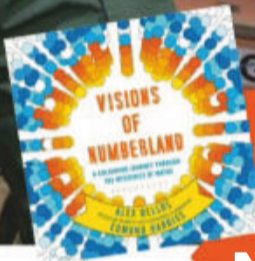

WIN!
AMAZING PRIZE FOR LETTER OF THE MONTH!
VISIONS OF NUMBERLAND

Go on a colouring journey through the mysteries of maths with this 'mathemagical' colouring book, with 60 patterns to colour and ten to create.

Digestion in space

Hi HIW,

Is it harder for the body to digest food in space compared to on Earth?

Eoghan Lough

Great question Eoghan! This is actually something researchers are still trying to understand and has been studied for quite some time. Several stages are undertaken within our bodies in order to digest food. As far as we know, there isn't much difference in the physical processes of digestion in space, such as chewing and the travelling of food to the stomach, also known as peristalsis.

However, our gut bacteria, a key part of our digestion, seems to be affected by the lack of gravity in space. Also known as the microbiome, trillions of bacteria help break down any food not fully digested by our intestines. Astronaut Scott Kelly spent 340 days on board the International Space Station (ISS) between 2015 and 2016. While there he

performed experiments to research the effects of microgravity on the human body, including studying his microbiome.

With his twin brother, Mark Kelly, still on Earth, researchers compared the brothers' microbiomes upon Scott's return from space. What they found was that, while in space, the balance of two key groups of bacteria fluctuated in Scott's gastrointestinal tract more than Mark's, then returned to normal back on Earth. It has been speculated that this may be the result of the clean astronaut food, or microgravity playing a part in the imbalance.

Further research is being conducted to evaluate space's effect on human digestion by introducing new rodent residents to the ISS to study their microbiomes. Ending this month, rats spending either 30 or 90 days on the ISS will be the subject of gastrointestinal function and metabolic function studies, so hopefully we will soon have a better idea of how digestion is affected in space.

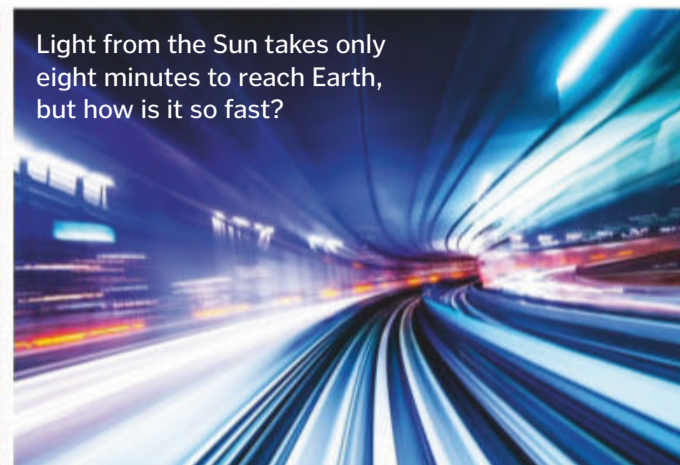

Light from the Sun takes only eight minutes to reach Earth, but how is it so fast?

Speed of light

Hi HIW,

I was talking to my friend the other day about light and the question, 'Why does light travel so fast?' came up. I hope you have an answer.

Bilbo Nutt

This is a tough question, and one physicists are still trying to answer. The speed of light is the known universe's speed limit - nothing can travel faster. To put it very generally, light has no mass and therefore doesn't play by the same quantum rules as objects with mass. It's affected differently when it passes through the Higgs field, a hypothetical quantum field, gaining energy rather than mass. Theoretically, without this quantum restriction light can reach the universe's ultimate speed.

Table of elements

Hi HIW,

What is the periodic table, and why was it made?

Isabel Daniells

A basic version of the modern periodic table has existed since 1869, and whose entries have grown since it was created by Russian chemist Dmitri Mendeleev. It's essentially a dictionary for chemistry, showcasing all the known chemical elements - over 100 of them - arranged in order of increasing atomic number (the number of protons in the atomic nucleus) in horizontal rows called periods and vertical columns called groups. Elements in the same group have similar chemical properties. This arrangement makes it possible for scientists to predict the reactivity - if at all - of the different elements.

Slugs and slime

Hi HIW,

When I'm in the garden I often see trails left by snails and slugs. Could you tell me what the slime is that makes up the trail? Thanks.

Gemma Fishburne

The silvery trails left behind our garden gastropods play a vital part in their survival. The slime is made up from mucus and proteins, secreted from glands on its foot. The slime aids a snail's movement while acting as a glue to keep them stable on the ground. Though made up predominantly of water, the proteins within it help prevent the trail from evaporating, resulting in the slimy trail.



Snails use these slime trails to glide on the ground and keep them stable

Sea foam

Hi HIW,

I was walking along the beach the other day and there was a lot of foam still sitting on the sand, I was wondering if you can tell me what it was? Thanks.

Lucie Bridgewood

Thanks for your question, Lucie. This is typically known as sea foam and forms as a result of algal blooms far out at sea being washed up on the shore. When blooms of these aquatic organisms die, wind and waves churn up the organic matter into a floating froth that is deposited on the beach.



Sea foam is the result of dead algae drifting ashore

www.howitworksdaily.com

What's happening on...

social media?



This month, we asked you what you think the next technological breakthrough will be and why.

@bicyclegasoline

"Smart nappies that alert your phone when they need changing"

@janesgrapevine

"Teleportation – it would cut transport costs, reduce congestion and massively reduce our carbon footprint"

@DarrenBarnard1

"Clothing that will store reusable energy from everyday human movement – eco tech is the future"

@angep1969

"Gosh I almost can't imagine. I think it will revolve around VR. Maybe a VR diet that fools your brain into thinking you've eaten more than you have!"

@ruth_pickford

"I think it will be cars that are self driven... controlled by chip"

@SuperLuckyDi

"Contact lenses that take photos and send to your phone!"

NEXT ISSUE...

Issue 124 on sale
18 APR 2019

Available in print from all good newsagents and myfavouritemagazines.co.uk, or as a digital edition for iOS and Android. To enjoy savings on the RRP and to make sure you never miss an issue, check out our subscription offers on pages 30 (UK) and 77 (US).

HOW IT WORKS

Future PLC Richmond House, 33 Richmond Hill, Bournemouth, Dorset, BH2 6EZ

Editorial

Editor **Ben Biggs**
Senior Art Editor **Duncan Crook**
Research Editor **Baljeet Panesar**
Production Editor **James Price**
Staff Writer **Scott Dutfield**
Editor-in-Chief **Gemma Lavender**

Contributors

Adrian Mann, Ed Crooks, James Horton, Joanna Stass, Jodie Tyley, Jonathan O'Callaghan, Laura Mears, Nicholas Forder, Stephen Ashby, Steve Wright, The Art Agency, Tom Lean, Timothy Williamson, Lee Cavendish, Jack Griffiths, Amy Grisdale, Alex Pang, Josh Russell, Katharine Marsh, Nikole Robinson

Cover images

Adrian Mann; Nicholas Forder; Digisole; MOD; Getty; Alamy; NASA

Photography

Alamy, Getty Images, NASA, Science Photo Library, Shutterstock, Thinkstock, Wikimedia
All copyrights and trademarks are recognised and respected

Advertising

Media packs are available on request
Commercial Director **Clare Dove**
clare.dove@futurenet.com
Group Advertising Director **Mark Wright**
mark.wright@futurenet.com
Advertising Manager **Toni Cole**
toni.cole@futurenet.com
01225 687368
Media Sales Executive **Jagdeep Maan**
jagdeep.maan@futurenet.com
01225 687353

International

How It Works is available for licensing. Contact the International department to discuss partnership opportunities
Head of Print Licensing **Rachel Shaw Rachel Shaw**
licensing@futurenet.com

Subscriptions

Email enquiries contact@myfavouritemagazines.co.uk
UK orderline & enquiries **0344 848 2852**
Overseas order line and enquiries **+44 (0)344 848 2852**
Online orders & enquiries www.myfavouritemagazines.co.uk
Head of subscriptions **Sharon Todd**

Circulation

Head of Newstrade **Tim Mathers**

Production

Head of Production **Mark Constance**
Production Project Manager **Clare Scott**
Advertising Production Manager **Joanne Crosby**
Digital Editions Controller **Jason Hudson**
Production Manager **Vivienne Calvert**

Management

Managing Director **Alastair Lewis**
Chief Content Officer **Aaron Asadi**
Commercial Finance Director **Dan Jotcham**
Editorial Director **Paul Newman**
Head of Art & Design **Greg Whittaker**

Printed by William Gibbons & Sons Limited, 26 Planetary Road, Willenhall, Wolverhampton, West Midlands, WV13 3XB

Distributed by Marketforce, 5 Churchill Place, Canary Wharf, London, E14 5HU www.marketforce.co.uk Tel: 0203 787 9001

ISSN 2041-7322

We are committed to only using magazine paper which is derived from responsibly managed, certified forestry and chlorine-free manufacture. The paper in this magazine was sourced and produced from sustainable managed forests, conforming to strict environmental and socioeconomic standards. The manufacturing paper mill holds full FSC (Forest Stewardship Council) certification and accreditation

All contents © 2019 Future Publishing Limited or published under licence. All rights reserved. No part of this magazine may be used, stored, transmitted or reproduced in any way without the prior written permission of the publisher. Future Publishing Limited (company number 2008885) is registered in England and Wales. Registered office: Quay House, The Ambury, Bath BA1 1UA. All information contained in this publication is for information only and is, as far as we are aware, correct at the time of going to press. Future cannot accept any responsibility for errors or inaccuracies in such information. You are advised to contact manufacturers and retailers directly with regard to the price of products/services referred to in this publication. Apps and websites mentioned in this publication are not under our control. We are not responsible for their contents or any other changes or updates to them. This magazine is fully independent and not affiliated in any way with the companies mentioned herein.

If you submit material to us, you warrant that you own the material and/or have the necessary rights/permissions to supply the material and you automatically grant Future and its licensees a licence to publish your submission in whole or in part in any/all issues and/or editions of publications, in any format published worldwide and on associated websites, social media channels and associated products. Any material you submit is sent at your own risk and, although every care is taken, neither Future nor its employees, agents, subcontractors or licensees shall be liable for loss or damage. We assume all unsolicited material is for publication unless otherwise stated, and reserve the right to edit, amend, adapt all submissions.

ipso. Regulated



Future plc is a public company quoted on the London Stock Exchange (symbol: FUTR) www.futureplc.com

Chief executive **Zillah Byng-Thorne**
Non-executive chairman **Richard Huntingford**
Chief financial officer **Penny Ladkin-Brand**

Tel +44 (0)1225 442 244

FAST FACTS

Amazing trivia to blow your mind

ONE BITE OF AUSTRALIA'S
INLAND TAIPAN CONTAINS
ENOUGH VENOM TO KILL
100 ADULT HUMANS

40,000 VOLTS

THE OUTPUT SUPPLIED BY THE ION WIND
PLANE'S BATTERIES

45 KILOGRAMS

THE AMOUNT OF MEAT A WILD TIGER
CAN EAT IN ONE SITTING

100 MILLION
DEGREES CELSIUS

THE OPERATING TEMPERATURE OF
PLASMA IN A TOKAMAK FUSION REACTOR

585
PAGES

THE SIZE OF THE UK'S EU
WITHDRAWAL AGREEMENT TEXT

-179°
CELSIUS

THE AVERAGE
SURFACE
TEMPERATURE
OF SATURN'S
MOON, TITAN

**VICTORIANS
INVENTED THE
TRADITION
OF SENDING
CHRISTMAS
CARDS IN 1843**

4 MILLION
TONS

THE AMOUNT OF MATTER THE SUN
CONVERTS INTO ENERGY EVERY SECOND

**BRAILLE IS A UNIVERSAL CODE THAT
ANY NATIVE LANGUAGE SPEAKER, BLIND
OR SIGHTED, CAN UNDERSTAND**

93 BILLION
LIGHTYEARS

THE ESTIMATED DIAMETER OF THE UNIVERSE

500 A SINGLE FRUIT FLY CAN LAY HUNDREDS
OF EGGS IN ITS 40-DAY LIFE SPAN

POWERBALL® GYROSCOPES

DEVELOP YOUR OWN GRAVITATIONAL FORCES...LIKE TINY SPINNING PLANETS



280 Classic
The Entry One



280 Autostart Classic
The All Round One



Diablo Evo Autostart
The Muscle One



280 Autostart Pro
The Best Selling One

Titan

The Most Powerful One



280 Autostart Fusion
The Amazing One

amazon



Over one thousand
5-star reviews

 **powerballs.com**

A zero gravitational training aid for NASA astronauts, Powerball® develops over 60 times its own weight in gyroscopic resistance and delivers strengthening and rehabilitation for the arms & wrists unlike anything else on (or off) this planet.